

Semester : 4<sup>th</sup> B. Tech (V Deans')

Course No. : FMPE-2.4.4

Subject : Tractor and Automotive Engines

## LESSON 1

### STUDY OF SOURCES OF FARM POWER –CONVENTIONAL & NON-CONVENTIONAL ENERGY SOURCES

In Agriculture production system various energy sources are used and converted into intended work output. Where agriculture has to face the challenges of region specific climatic changes/fluctuations and also the market forces in today's global economy, the timeliness of farm operations and availability of adequate farm power become very crucial for increasing production and productivity and handling the crop produce and also to reduce losses. With the increase in cropping intensity the turn around time is drastically reduced and it is not possible to harvest and thresh the standing crop and prepare seed bed and do timely sowing operations of subsequent crop in the limited time available, unless adequate farm power is available. Agricultural labour, draught animals, tractors, power tillers, diesel engines and electric motors are the major sources of power used for farm operations.

The usage of tractor and electro-mechanical (diesel engines& electric motors) farm power sources has been increasing continuously in Indian agriculture. The bullock drawn cultivation where draft animals were being used, tractors and power tillers have replaced draft animals as the major source of farm energy. Similarly, the availability of human labour for farm operations is also decreasing with time which results into adoption of alternate energy sources to do various farm operations.

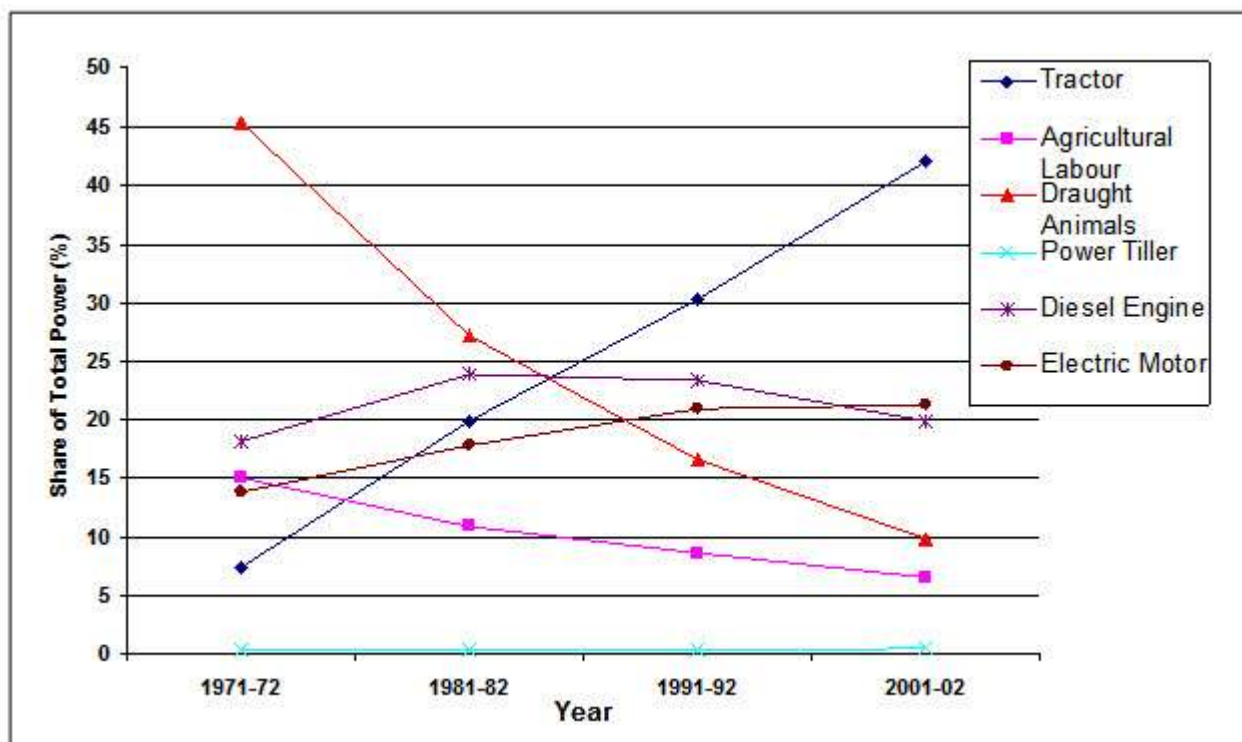

## Farm power usage and farm productivity

Regions with high agricultural productivity use very high level of farm power as compared to developing countries which usually have low levels of agricultural productivity. This can be clearly observed from the trends shown in past few decades in India, where agricultural productivity has grown significantly with the increase in farm power (kW/ha) availability over the years and also in the specific regions/states of the country, agricultural productivity has the direct relation with farm power availability. States with more farm power usage for performing timely operations, have more agricultural productivity.

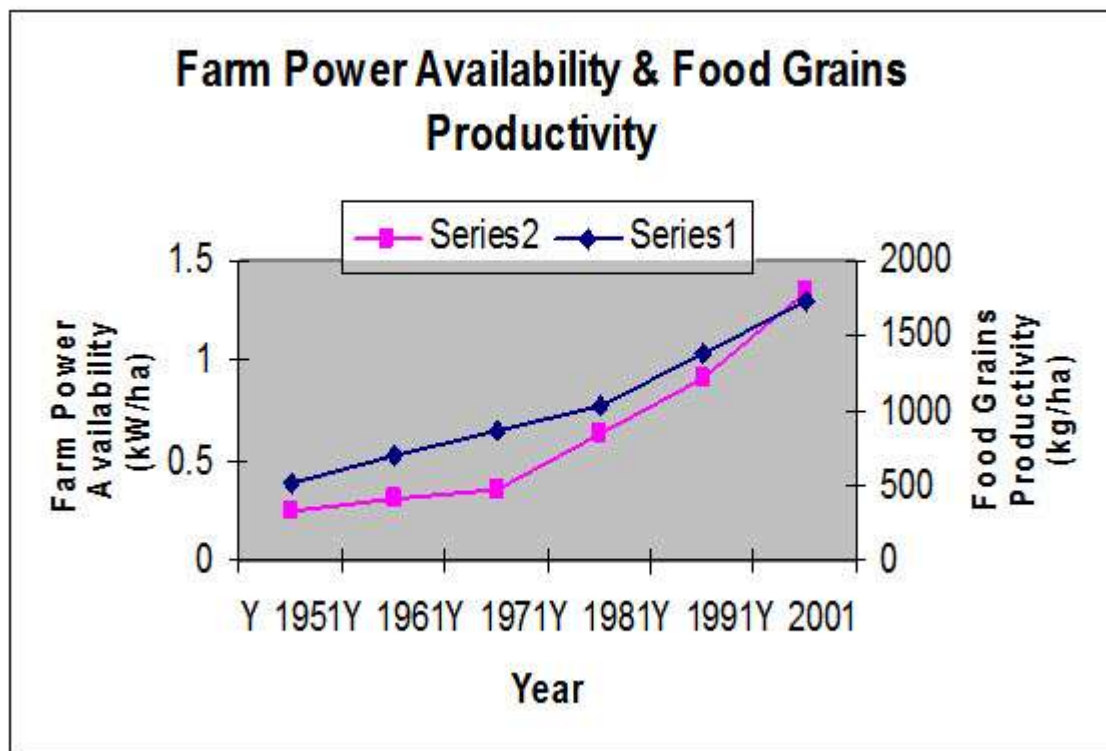

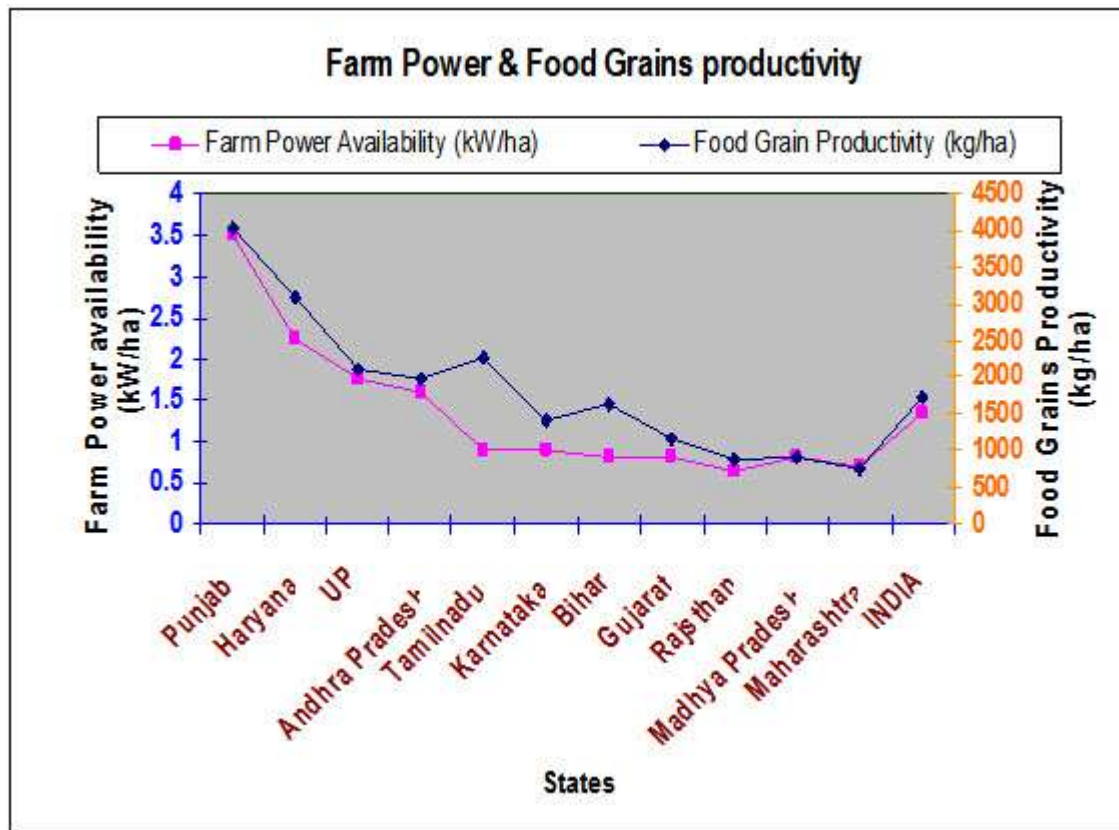

#### Timeliness cost

Another aspect of energy consumption pattern in agriculture is of its peculiar nature. Agriculture is a seasonal industry where demand of energy fluctuates throughout the year and varies with crop production requirements. There are certain months of the year when agriculture demands more energy to meet its requirements to complete the crucial operations like sowing, transplanting, harvesting & threshing etc. in time. The delay in farm operations may result into increase in timeliness losses which further leads to decrease in the overall profitability of farm. These fluctuations in farm energy requirements must be taken into considerations while planning the resources to meet the energy demand of agriculture fully.

## LESSON 2

### CLASSIFICATION OF TRACTORS AND IC ENGINES

Tractors had been introduced in the farming operations to replace the draft animals. With the advancement of crop production techniques being used in the agriculture the designs of tractors have also been improved a lot worldwide. Depending upon crops and special farm operations to be performed in different agro-climatic conditions various types of tractors have been developed and introduced. Following are the various types of tractors being used these days on farm for agriculture purposes.

#### ➤ Types of tractors

- **Two wheel drive tractors** : In this type of tractors, the traction power is provided on the rear wheels whereas the front tyres are used as steering tyres which are generally smaller in size as compared to rear wheels. Mostly, these two wheel drive tractors are considered as

general purpose tractors and are being used widely from lower power range say 20 hp to 60 hp. Track width (centre to center distance between two tyres on the same axle) can adjusted to use these tractors for various agronomic practices in crop production.

- **Four wheel drive tractors** : The traction power is provided to all four tyres of the tractors to perform highly loaded farm operations. These tractors are used in soft soils and wet lands where high traction is required to reduce the slippage and increase the drawbar power. Four wheel drive tractors are available in the power range from 60 hp to even more than 300 hp in the different parts of the world.
- **Row crop tractors** : These tractors are also known as standard row-crop tractors. The width of tyres (front and rear) can be adjusted according to the spacing required for various farm operations to be done in the row crops.
- **Orchard tractors** : These tractors have been developed to farm operations specifically in orchards. Special considerations are given to the emission norms and location of exhaust muffler to avoid any damage to the trees.
- **High clearance tractors** : Ground clearance is kept significantly high in these tractors to be used in crops having plant height relatively more and requires interculture, weeding and spraying operations to be performed till maturity. The high clearance prevents the mechanical damage to the plants.
- **Crawler tractors** : These are slow speed tractors which are used for performing farm operations like seeding, spraying etc. having forward speed even less than 1 km/h. Sometimes creeper gears are also provided to make tractor crawl at very low forward speed.
- **Track type tractors** : These tractors have tracks instead of wheels to improve traction in wet land cultivation. Special purpose tracks are used for tractors to be used for agricultural purposes.

#### ➤ **Engine Classifications**

With the advancement of technology in every sector, engine being prime mover or power house for any automobile or farm machinery, much has already been done in the development of engines for general purpose usage and special applications. So, engines can be classified in many ways depending upon their construction, operating principle, size, fuel used etc..

#### ➤ **Types of engines depending on method of ignition**

- **Spark Ignition (SI)** : Spark plug is used in SI engines to initiate the combustion process in each cycle with the help of a high voltage electrical discharge between two electrodes. The air fuel mixture in the combustion chamber is ignited by the plug. Earlier the torch holes were being used to start combustion from external flame and then with the technological advancements electric spark plug replaced these torch holes.

(i) Carbureted: A device for mixing air and fuel to facilitate the combustion process

(ii) Multipoint port fuel injection: One or more injectors at each cylinder intake.

(iii) Throttle body fuel injection: Injectors upstream in intake manifold.

(iv) Gasoline direct injection: Injectors mounted in combustion chambers with injection directly into cylinders.

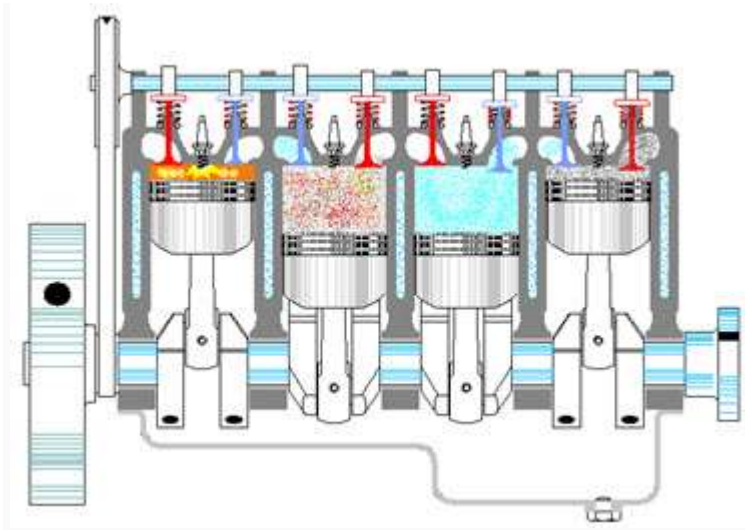

- **Compression Ignition (CI)** : The combustion process in a CI engine starts when the air-fuel mixture self-ignites due to high temperature in the combustion chamber caused by high compression.

(i) Direct injection: Fuel injected into main combustion chamber.

(ii) Indirect injection: Fuel injected into secondary combustion chamber.

#### ➤ **Types of engines depending on Engine cycle**

- **Four-stroke cycle:** A four-stroke cycle has four piston movements over two engine revolutions for each cycle.
- **Two-stroke cycle:** A two-stroke cycle has two piston movements over one revolution for each cycle.

#### ➤ **Types of engines depending on Valve location**

- Valves in head (Overhead valve), also called I Head engine.
- Valves in block (flat head), also called L Head engine. Some historic engines with valves in block had the intake valve on one side of the cylinder and the exhaust valve on the other side. These were called T Head engines.
- One valve in head (usually intake) and one in block, also called F Head Engine; this is much less common.

#### ➤ **Types of engines depending on Position and number of cylinders**

- **Single Cylinder:** Engine has one cylinder and piston connected to the crankshaft.
- **In-Line:** Cylinders are positioned in a straight line, one behind the other along the length of the crankshaft. They can consist of 2 to 11 cylinders or possibly more. In-line four-cylinder engines are very common for automobile and other applications. In-line six and eight cylinders are historically common automobile engines. In-line engines are sometimes called Straight (e.g., straight six or straight eight).

- **V Engine:** Two banks of cylinders at an angle with each other along a single crankshaft, allowing for a shorter engine block. The angle between the banks of cylinders can be anywhere from 15° to 120° with 60°-90°. V engines usually have even numbers of cylinders from 2 to 20 or more.
- **Opposed Cylinder Engine:** Two banks of cylinders opposite to each other on a single crankshaft (a V engine with 180 deg V). These are common on small aircraft and some automobiles with an even number of cylinders from two to eight or more. These engines are often called flat engines (e.g., flat four).
- **Opposed piston engine:** Two pistons in each cylinder with the combustion chamber in the center between the pistons. A single combustion process causes two power strokes at the same time, with each piston being pushed away from the center and delivering power to a separate crankshaft at each end of the cylinder. Engine output is either on two rotating crankshafts or on one crankshaft incorporating a complex mechanical linkage. These engines are generally of large displacement, used for power plants, ships, or submarines.
- **Radial engine:** Engines with pistons positioned in a circular plane around a circular crankshaft. The connecting rods of the piston are connected to a master rod, which in turn, is connected to the crankshaft. A bank of cylinders on a radial engine almost always has an odd number of cylinders ranging from 3 to 13 or more. Operating on a four-stroke cycle every other cylinder fires and has a power stroke as the crankshaft rotates, giving a smooth operation. Many medium and large size propeller driven aircraft use radial engines.

#### ➤ **Types of engines depending on Air Intake Process**

- **Naturally Aspirated:** No intake air pressure boosts system.
- **Super charged:** Intake air pressure increased with the compressor driven off of the engine crankshaft.
- **Turbo charged:** Intake air pressure increased with the turbine compressor driven by the engine exhaust gases.
- **Crankcase compressed:** Two-stroke cycle engine which uses the crankcase as the intake air compressor. Limited development work has also been done on design and construction of four-stroke cycle engines with crank case compression.

#### ➤ **Types of engines depending on Fuel used**

- Petrol/Gasoline engines
- Diesel engines
- Gas, Natural gas, Methane engines
- Alcohol-Ethyl, Methyl engines
- **Dual fuel engines:** There are a number of engines that use a combination of two or more fuels. Some, Usually large, CI engines use a combination of natural gas and diesel fuel. These are attractive in developing third world countries because of the high cost of the diesel fuel. Combined gasoline alcohol fuels are becoming more common as an alternative to straight gasoline automobile engine fuel.



(f) Gasohol engines: Common fuel consisting of 90% gasoline and 10% alcohol.

➤ **Types of engines depending on Type of cooling**

- **Air cooled :** Circulating air is used to dissipate the heat from the fins on an engine. Mostly small engines are used with air cooled engines.
- **Liquid cooled, Water-cooled :** Water is made to flow through the water jackets provided along the surface of cylinders or liners to absorb the heat. Further the heated water is cooled with the help of radiator.

### LESSON 3

#### CI AND SI ENGINE

**Basic Engine cycles:** Most internal combustion engines both spark ignition and compression ignition operates on either a four stroke cycle or a two stroke cycle. These basic cycles are fairly standard for all the engines.

➤ **Four stroke Spark Ignition (Petrol) engine**

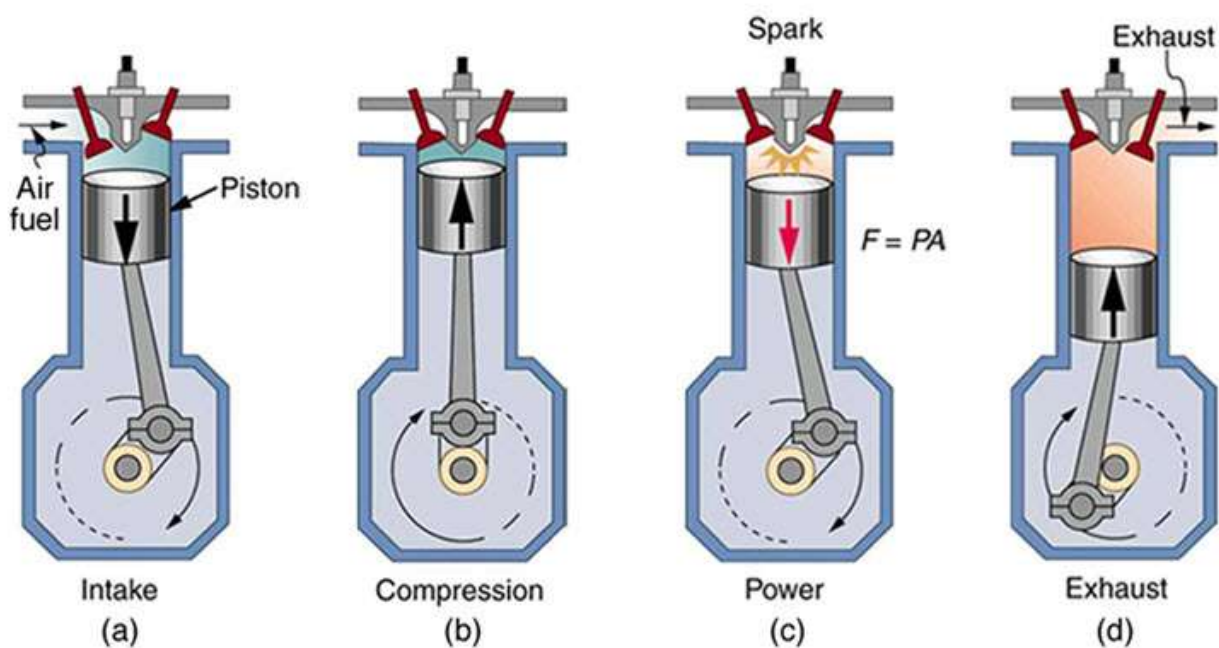

**First stroke : Suction stroke**

It is also known as intake stroke when the piston travels from TDC to BDC with the intake valve open and exhaust valve closed. The downward motion of the piston increases the volume in the combustion chamber which in turn creates a vacuum. The resulting pressure differential through the intake system from atmospheric pressure on the outside to the vacuum on the inside causes air to be pushed into the cylinder. As the air passes through the intake system, fuel is introduced into the cylinder in the desired amount with the help of fuel injectors or carburetor.

**Second stroke : Compression stroke**

At the end of suction stroke, when the piston reaches BDC, the intake valve gets fully closed and the piston travels upward back to TDC with both the valves (inlet and outlet) closed. As the piston moves upward, it compresses the air-fuel mixture raising both the pressure and the temperature inside the cylinder. Near the end of the compression stroke, the combustion is initiated with the

help of spark plug. The combustion of an air-fuel mixture occurs in a very short but finite length of time with the piston near TDC. Combustion changes the composition of the gas mixture to that of exhaust products and increases the temperature in the cylinder to a very high peak value.

### Third stroke : Power stroke

This is also known as the expansion stroke when the piston moves again downward from TDC with the pressure being generated by the fuel burnt having both the valves fully closed. This is the stroke which produces the work output of the engine cycle. As the piston travels from TDC to BDC, cylinder volume is again increased causing pressure and temperature drop. Late in the power stroke, the exhaust valve is opened and exhaust blow down occurs. The pressure and temperature in the cylinder are still high relative to the surroundings at this point and a pressure differential is created through the exhaust system when the piston is near BDC. Opening the exhaust valve before the piston reaches BDC, reduces the work obtained during the power stroke but is required because of the finite time needed for exhaust blow down.

### Fourth stroke: Exhaust stroke

By the time the piston reaches BDC during the power stroke, the cylinder is still full of exhaust gases. With the exhaust valve remaining open, the piston now travels upward to make the gases move out of the cylinder into the exhaust system, leaving only that amount of exhaust gasses which are trapped in the clearance volume when the piston reaches TDC. Near the end of exhaust stroke, the intake valve starts to open, so that it is fully open by TDC to start the new intake stroke in the next cycle. Near TDC exhaust valve starts to close and finally is fully closed sometime at TDC. This period when both intake valve and exhaust valve are open is called valve overlap.

### ➤ Four stroke Compression Ignition (Diesel) engine

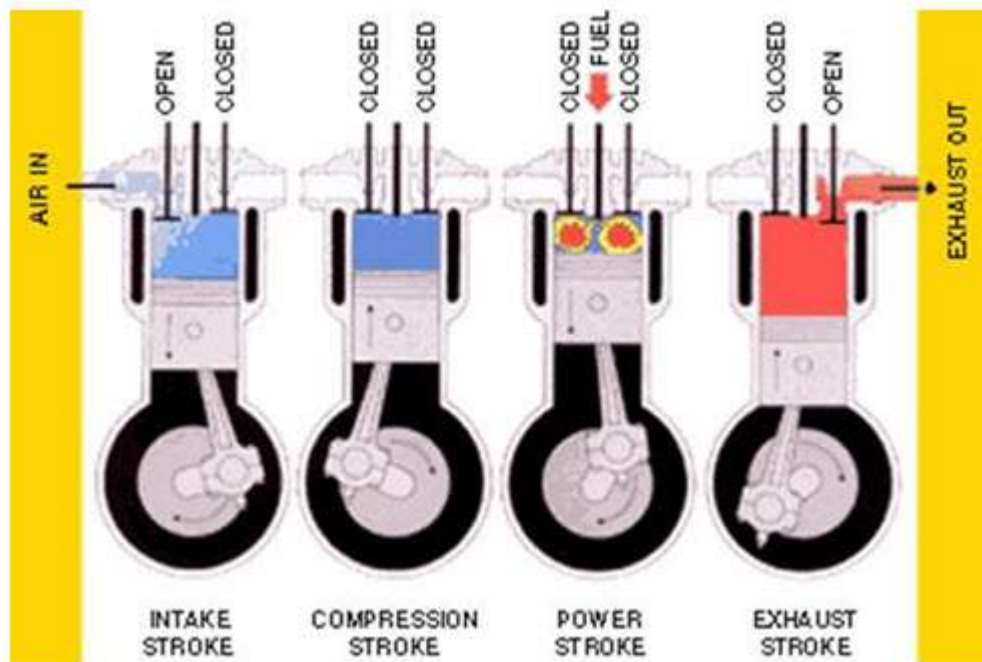

**First stroke: Intake stroke:** The same as the intake stroke in the SI engine with one major difference: no fuel is added to the incoming air.



**Second stroke: Compression stroke:** The same as in an SI engine except that only air is compressed and compression is to higher pressures and temperature. Late in the compression stroke fuel is injected directly into the combustion chamber when it mixes with very hot air. This causes the fuel to evaporate and self ignite, causing combustion to start. Combustion is fully developed by TDC and continues at about constant pressure until the fuel injection is complete and the piston has started towards BDC.

**Third stroke: Power stroke:** The power stroke continues as combustion ends and the piston travels towards BDC. Exhaust Blowdown is same as with an SI engine.

**Fourth stroke: Exhaust stroke:** Same as with an SI engine

#### ➤ Two stroke Spark Ignition (Petrol) engine

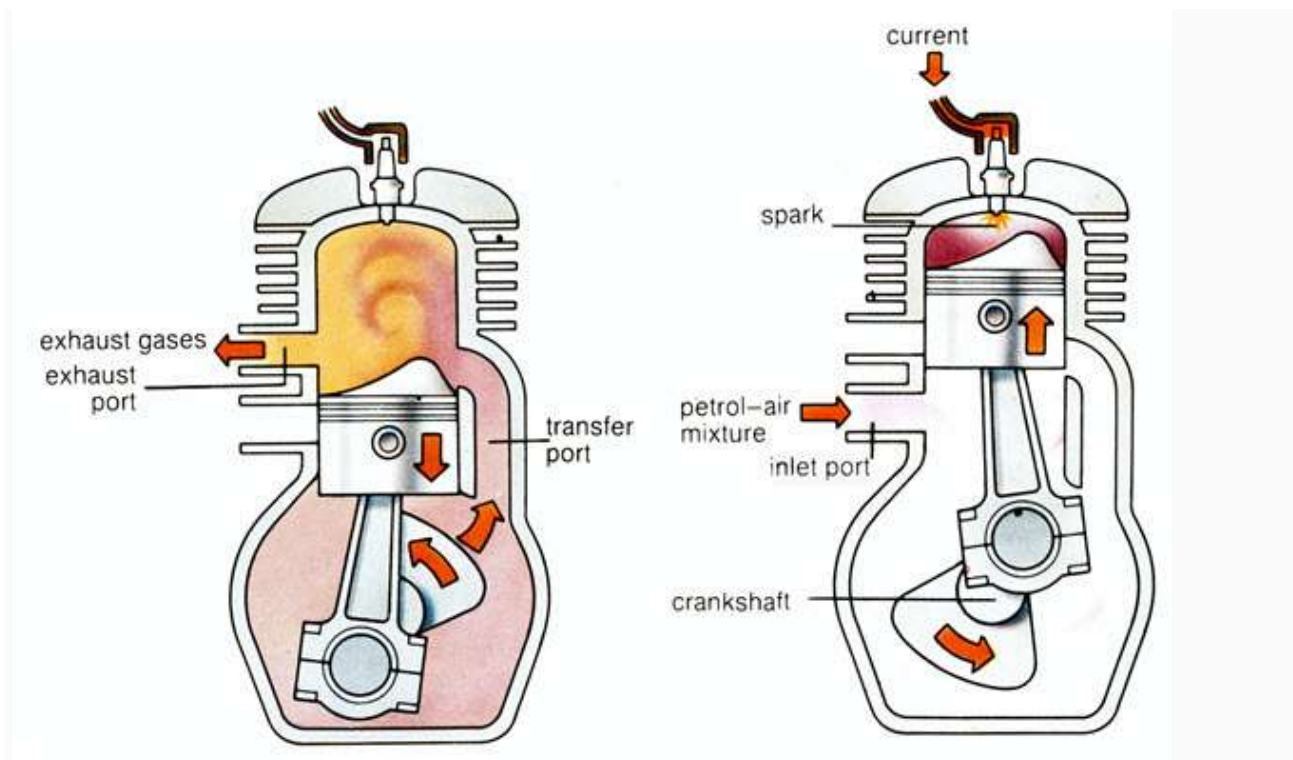

Instead of inlet and exhaust valves available in Four-Stroke spark ignition (petrol) and compression ignition (diesel) engines, Two-Stroke engines are equipped with inlet and outlet ports which are opened and closed with the reciprocating movement of piston only. In these engines the complete cycle of suction, compression, power and exhaust is performed with two strokes i.e one revolution of the crankshaft.

In two stroke engines, the air fuel mixture is entered from the carburetor through the inlet port at the bottom when the piston starts moving upward. The air fuel mixture is compressed at the same time during the same stroke, hence suction and compression are being performed simultaneously. When the piston reaches just at TDC, the combustion takes place and piston generates movement to the crankshaft. As the piston moves downward with power stroke, it compresses the mixture in crankcase to move into cylinder through the transfer port which pushes the out the burnt/exhaust gases to move out from the exhaust port. And at the same time, new charge (air fuel mixture) start entering through the inlet port, this process is also know as cross-flow scavenging. In this way, all

four strokes of engine cycle are completed in the two strokes (one upward and one downward movement of piston) only.

## LESSON 4

### ENGINE TERMINOLOGY & DEFINITIONS

Various standard terminologies and abbreviations are being used while understanding and elaborating the engine concepts.

**Internal Combustion (IC) :** The engines where combustion takes place inside the cylinder, they are known as Internal Combustion (IC) engines. Majority of the engines being used for various applications are IC engines only. Although in early stages of engine developments, pre combustion chambers were also being used to inject the pre ignited charge (air fuel mixture) into the cylinder.

**Spark Ignition (SI):** When a beam of external spark with the help of spark plug is used to initiate the combustion process in each cycle, it is known as spark ignition (SI). (c) **Compression Ignition(CI):** When in an engine, the combustion process starts with the self ignition of air fuel mixture due to high temperature in the combustion chamber caused by the high compression, it is known as CI engines. Diesel engines particularly are the CI engines.

**Top-Dead-Center (TDC):** During the reciprocating motion of piston in the cylinder, position of the piston when is at the furthest point away from the crankshaft, it is known as the TDC. In some engines top-dead-center is not at the top of the engine (e.g., horizontally opposed engines, radial engines, etc.), some sources call this position Head-End-Dead-Center (HEDC). Some sources call this position Top-Center (TC). When the piston is at TDC, the volume in the cylinder is a minimum called the clearance volume.

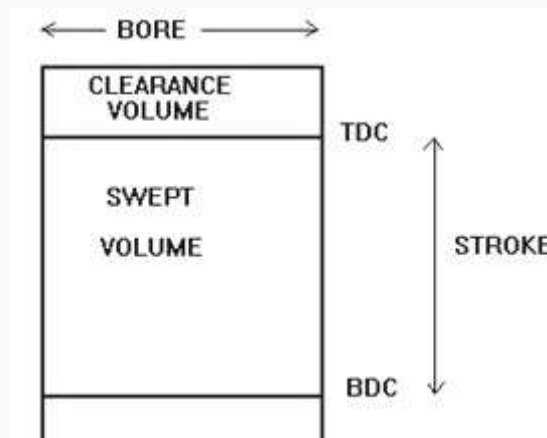

**Bottom-Dead-Center (BDC):** Same way, during the reciprocating motion, position of the piston when it stops at the point closest to the crankshaft refers to as BDC. Some sources call this Crank-End-Dead-Center (CEDC) because it is not always at the bottom of the engine. Some sources call this point Bottom Center (BC).

**Direct Injection (DI):** When fuel is injected directly into the main combustion chamber of an engine, it is known as DI engines.

**Indirect injection (IDI):** Rather than fuel injected directly into the combustion chamber or cylinder, the fuel is injected into the pre-combustion chamber of an engine for partial its burning.

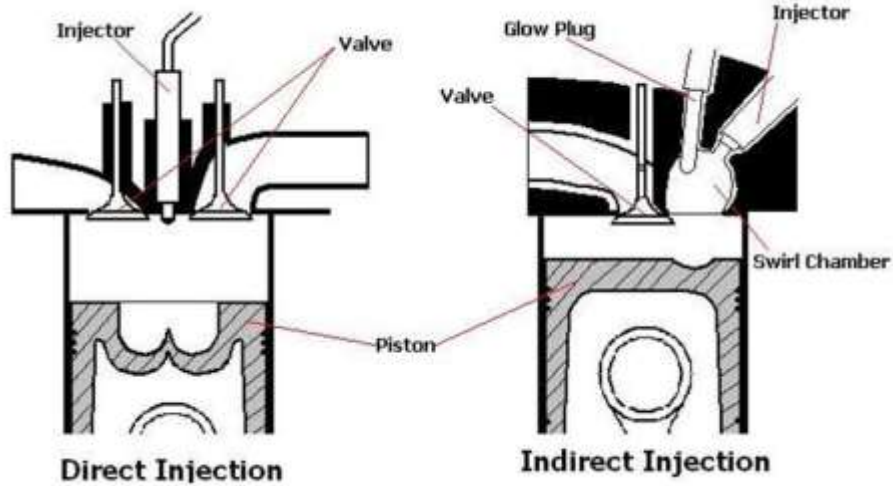

**Bore:** The inner diameter of the cylinder is known as the bore which is actually equal to sum of the diameter of the piston and a very small clearance between the piston and cylinder wall.

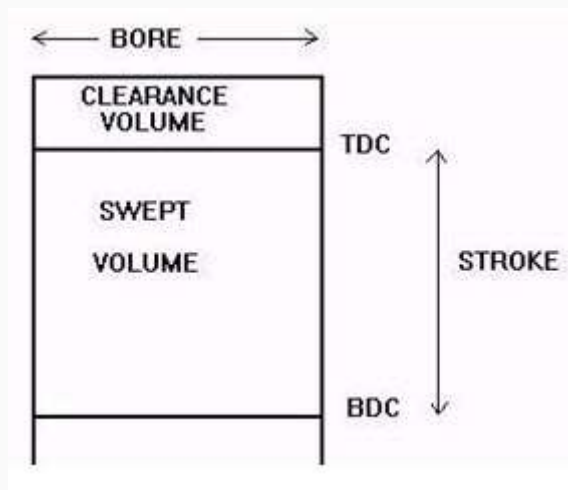
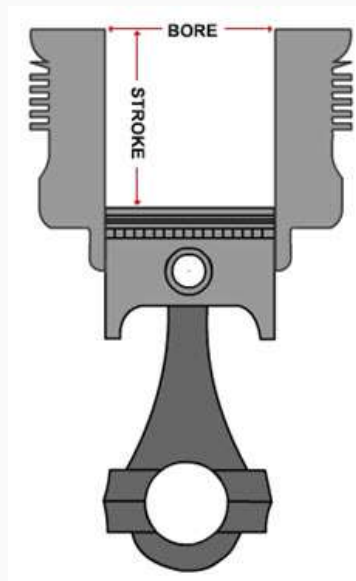

**Stroke:** Movement distance of the piston from one extreme position to the other: TDC to BDC or BDC to TDC.

**Clearance volume:** Minimum Volume in the combustion chamber with piston at TDC is called clearance volume.

**Displacement volume:** Volume displaced by the piston as it travels through one stroke i.e TDC to BDC or BDC to TDC. Displacement can be given for one cylinder or for the entire engine (displacement in one cylinder multiplied by number of cylinders). Displacement volume is also known as swept volume.

**Compression ratio :** It is the ratio of total cylinder volume with piston at BDC (Piston displacement + clearance volume) to the combustion chamber volume (clearance volume) with piston at TDC. Compression ratio varies from 14:1 to 20:1 for diesel engine and 4:1 to 8:1 for petrol engines.

**Ignition Delay (ID):** Time interval between ignition initiation and the actual start of combustion is called ignition delay..

**Air Fuel Ratio:** Ratio of mass air to mass of fuel input into engine. The power generation by the engine varies with the air fuel ratio. Due to slow burning of too lean mixture of fuel causes loss of power. Maximum economy lies between 13.5:1 to 15:1 air fuel ratio.

### ➤ Engine performance characteristics

The engine performance in terms of power, torque, engine speed, fuel consumption and efficiency is evaluated on the basis of purpose it is being used. In case of tractor engines, if farmer needs more power to pull the tillage implement, it must have high drawbar power and similarly if it requires more power to do the farm operations using rotary power, then engine in tractor must provide maximum PTO power. To relate the engine performance with economy of its usage, specific fuel consumption is also determined. Following are the most commonly used curves to rate the engine performance.

### Engine speed vs Torque

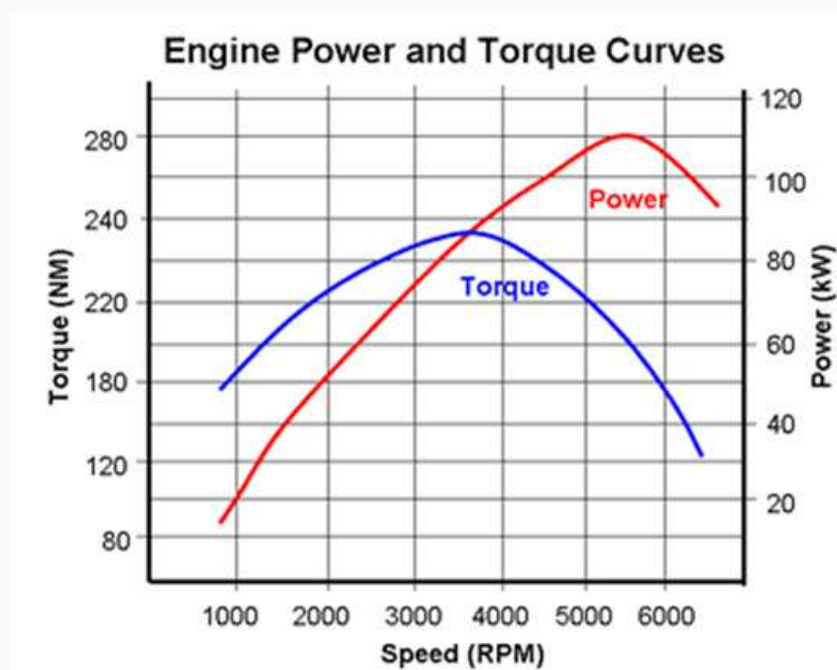

### Engine speed vs Indicated power, Brake Power & Mechanical efficiency

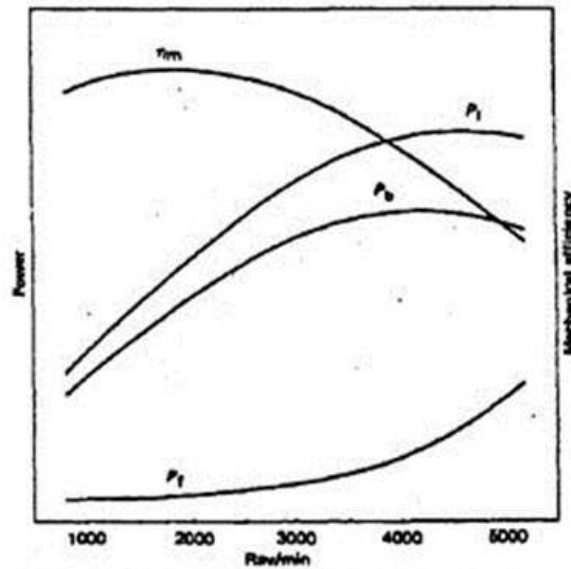

Fig. Indicated power ( $P_i$ ), brake power ( $P_b$ ), mechanical efficiency ( $\eta_m$ ) and frictional power ( $P_f$ ) plotted on a rev/min base.

## LESSON 5

### ENGINE COMPONENTS THEIR CONSTRUCTION, OPERATING PRINCIPLES AND FUNCTIONS

**Engine components:** Every component has its own significance in the smooth and desired functioning of an engine. The various components are constructed and manufactured keeping in view the design and performance features of the engine.

**Block:** Body of engine containing the cylinders made of cast iron or aluminum. The engine block is machined with multiple tools (manually or CNCs, the computer numerically machines) to fix the other components. The block of water cooled engines includes a water jacket cast around the cylinders. In air cooled engines the exterior surface of the block has cooling fins.



**Head:** The component that closes the end of cylinders, usually containing part of the clearance volume of the combustion chamber is called head. The head is usually made up of cast iron or aluminum, and bolts to the engine block. The head contains spark plug in the SI engines, and the fuel injectors in CI engines and some SI engines. Most modern engines have the valves in the head and many have the camshafts also positioned there (overhead valves and over head cam).

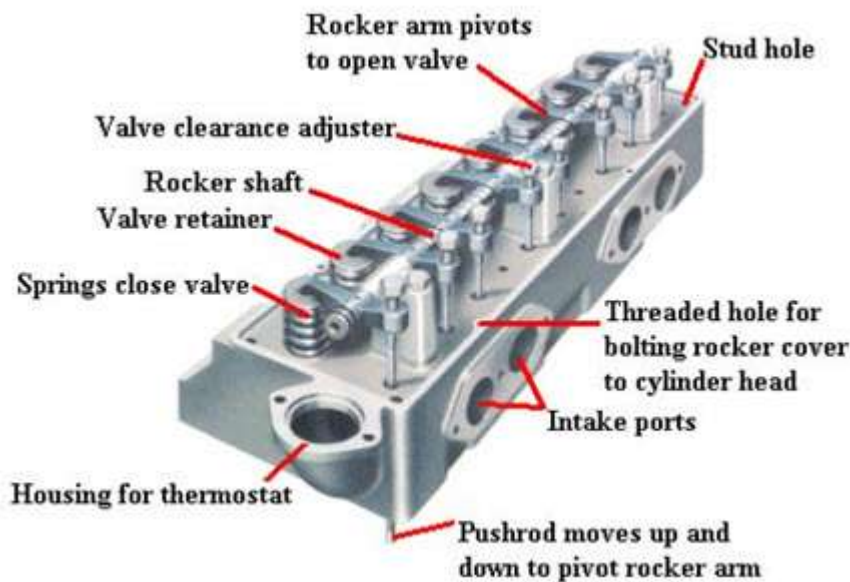

**Head gasket:** It is the gasket that serves as a sealant between the engine block and the head where they bolt together to avoid any leakage and pressure loss. The gaskets are usually made in sandwich construction of metal and composite materials. Some engines use liquid head gaskets also.



**Cylinders:** The circular cylinders in the engine block in which the pistons reciprocate back and forth. The walls of the cylinder have highly polished hard surfaces. Cylinders may be machined directly in the engine block or hard metal (drawn steel) sleeve may be pressed into the softer metal block also known as liners. Sleeves may be dry sleeves, which do not contact the liquid in the water jacket or wet sleeves which form part of the water jacket. With the advancement of engines design and manufacturing techniques being used and also due to additional advantages, the replaceable liners are getting more popularity these days.

**Piston:** The cylindrically shaped mass that reciprocates back and forth in the cylinder, transmitting the pressure forces being generated by the fuel burnt in the combustion chamber for rotating the crankshaft is called piston. The top of the piston is called crown and the sides are called skirt. The face on the crown makes up one wall of the combustion chamber and may be a flat or highly contoured surface. Some pistons contain an indented bowl in the crown which makes up a large percent of clearance volume. Pistons are made of alloy steel. Pistons have lower thermal expansion which allows for higher tolerances. Aluminum pistons are lighter and have less mass inertia.



Sometimes synthetic or composite materials are used for the body of the piston, with only the crown made of metal. Some pistons have a ceramic coating on the face.

**Piston pin :** Pin fastening the connecting rod to the piston is called piston pin and also called wrist pin.

**Piston rings:** These are the metal rings that fit into circumferential grooves around the piston and form a sliding surface against the cylinder walls. Near the top of the piston are usually two or more compression rings made with highly polished surfaces. The purpose of the rings is to form a seal between the piston and cylinder walls and to restrict the high pressure gases in the combustion chamber from leaking pass the piston into the crankcase (known as blow-by). Below the

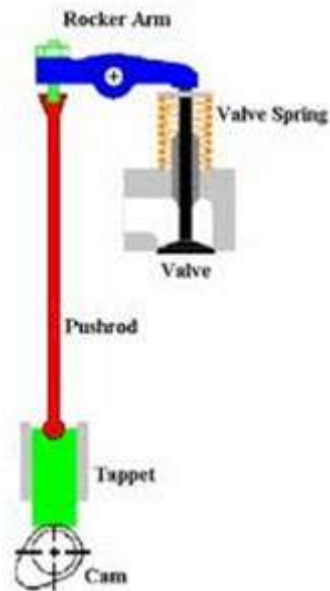

compression rings on the piston is at least one oil ring, which assists in lubricating the cylinder walls and scrapes away excess oil to reduce oil consumption.

**Valves :** These are used to allow flow of air and fuel or its mixture into and burnt/exhaust gases out of the cylinder at the proper time in the four stroke cycle engines. Most engines used poppet valves which are spring loaded closed, and pushed/open by camshaft action. Valves are mostly made of forged steel. Surfaces against which valves close are called valves seats and are made of hardened steel or ceramic. Two stroke cycle engines have ports (slots) in the side of cylinder walls instead of mechanical valves.

**Push rods:** It is the mechanical linkage between the camshaft and valves on over head valves engines used to operate the valve mechanism. Push rods have oil passages through there length as part of a pressurized lubrication system.



**Camshaft:** Rotating shaft used to operate the valves (intake and exhaust) at the proper time in the engine cycle either directly or through mechanical or hydraulic linkage (push rods, rocker arms, and tappets) is known as camshaft. Mostly engines have camshafts in the crank case but modern automobile engines have one or more camshafts mounted in the engine head known as overhead cams. These are generally made of forged steel or cast iron and driven by means of a belt or chain (timing chain). To reduce weight, some cams are made from a hollow shaft with the cam lobes press-fit on. In four stroke cycle engines the camshaft rotates at half engine speed.



**Crankshaft:** The rotating shaft through which engine work output is supplied to external systems is called crankshaft. The crankshaft is connected to the engine block with the main bearings. It is rotated by the reciprocating pistons through connecting rods connected to the crankshaft, offset from the axis of rotation. This offset is sometimes called Crankthrow or crank radius.



Most crankshafts are made of forged steel, while some are made of cast iron.

**Connecting rod:** Linkage used for connecting the piston with rotating crankshaft is called connecting rod. It is usually made of steel alloy forging or aluminum. Connecting rod is fastened to crankshaft with the help of bearing.

**Carburetor:** Venturi flow device that meters the proper amount of fuel into the air flow by means of pressure differential. For many decades it was the basic fuel metering system on all automobile (and other) engines. It is still used on low cost small engines having jets and float as the critical sub-components of a carburetor.

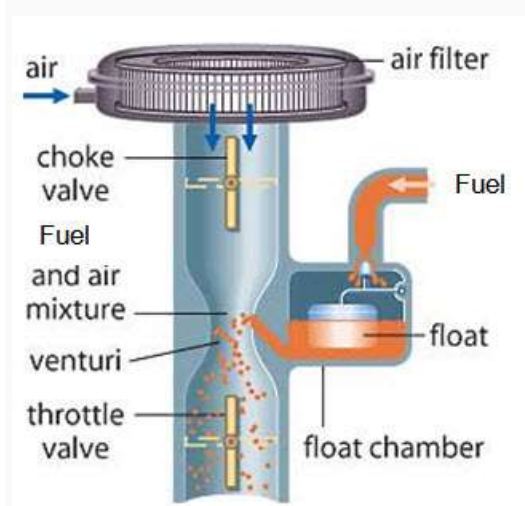

**Choke:** Butterfly valve at carburetor intake, used to create rich fuel-air mixture in intake system by choking/restricting the air intake for cold weather starting.



**Combustion chamber:** The end of the cylinder between the head and the piston face where the combustion occurs. The size of the combustion chamber continuously changes from a minimum volume when the piston is at TDC to a maximum when the piston is at BDC.

**Cooling fins:** The extended surfaces in the form of metal fins used air cooled engine on the outside surfaces of cylinders and head for cooling purposes by conduction and convection are known as cooling fins.

**Crankcase:** Part of the engine block surrounding the rotating crankshaft in many engines the oil pan makes up part of the crankcase housing. In some high performance engines the crankcase is designed with windows between the piston bays to allow free airflow between bays. This is to reduce air pressure build up on the backside of the pistons during power and intake strokes.

**Exhaust system:** The flow systems for removing exhaust gases from the cylinders, treating them and exhausting them to the surroundings. It consists of an exhaust manifold (piping systems usually made of cast iron that carries exhaust gases away from the engine cylinders) that carries the exhaust gases away from the engine, a thermal or catalytic converter to reduce emissions, a muffler to reduce engine noise and a tail pipe to carry the exhaust gases away from the passenger compartment.

**Fan:** Most engines have fan to increase air flow through the radiator and through the engine compartment which increases the heat removal from the engine for cooling purposes. Fans can be driven mechanically (with belt) or electrically, and can run continuously or be used only when needed.



**Flywheel :** It is the rotating mass with large moment of inertia connected to the crankshaft of the engine. The purpose of the flywheel is to store energy and furnish a large angular momentum that keeps the engine rotating between power strokes and smoothes out engine operation. In

multiple cylinder engines, the size of flywheel is relatively smaller than the single cylinder engines. On some aircraft engines the propeller serves as the flywheel.

**Fuel Injector :** A pressurized nozzle that sprays fuel into the incoming air in SI engines or into the cylinder in CI engines are known as fuel injectors. In SI engines, fuel injectors are located at the intake valve ports on multipoint port injection systems.

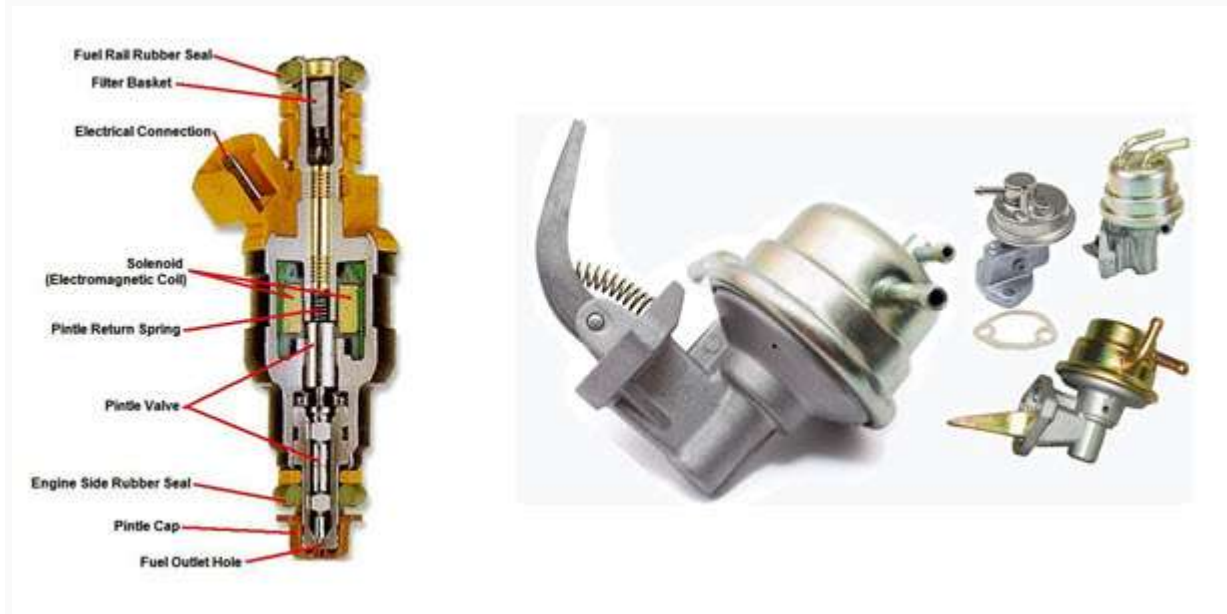

**Fuel pump:** Electrically or mechanically driven pump to supply fuel from the fuel tank (reservoir) to the engine is known as fuel pump. Many modern automobiles have an electrical fuel pump mounted submerged in the fuel tank. Fuel pumps are generally of two types ; inline pump (reciprocating type) for each cylinder or rotary pump (rotor type) common for all cylinders.

**Glow plug:** Small electrical heater resistance mounted inside the combustion chamber of many CI engines, used to preheat the chamber so that combustion will occur when first starting a cold engine. The glow plug is turned off after the engine is started.

**Intake Manifold:** Piping system that delivers incoming air to the cylinders usually made of cast metal, plastic, or composite material. In most SI engines, fuel is added to the air in the intake manifold system either by fuel injectors or with a carburetor. Some intake manifolds are heated to enhance fuel evaporation. The individual pipe to a single cylinder is called a runner.

**Main bearing:** The bearings connected to the engine block in which the crankshaft rotates are



called main bearings.

**Oil pan:** Oil reservoir usually bolted to the bottom of the engine block, making up part of the crankcase. It acts as the oil sump for most engines.

**Oil pump:** Pump used in force feed lubricating system to distribute oil from the oil sump to required lubrication points is called oil pump. The oil pump can be electrically driven but in most

cases it is mechanically driven by the engine. Some small engines do not have an oil pump and are lubricated by splash distribution.

**Oil sump:** It is the reservoir for the oil system of the engine, commonly part of the crankcase. Some automobile engines with overhead crankshafts have a secondary oil sump in the engine head to supply lubrication to the cam and valve mechanism. Some engines have a separate closed reservoir called a dry sump.

**Radiator :** Liquid to air heat exchanger of honey comb construction used to remove heat from the engine coolant is called radiator. The radiator usually mounted in front of the engine in the flow of air as the automobile moves forward. An engine drive or electric fan is often used to increase air flow through the radiator.



**Spark plug:** Electrical device used to initiate combustion in an SI engine by creating a high voltage discharge spark across an electrode gap. Spark plug is usually made of metal surrounded with ceramic insulation. Some modern spark plug has built-in pressure sensors that supply one of the inputs into engine control.

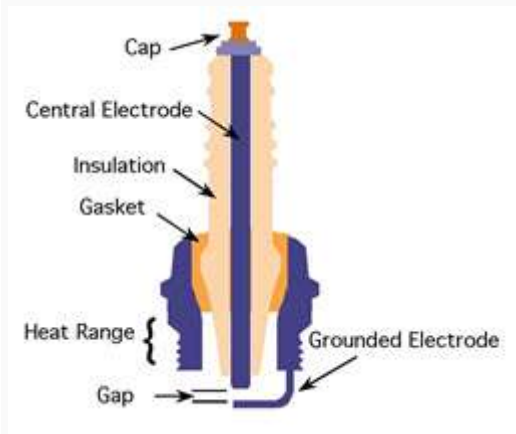

**Water jacket :** System of liquid flow passages surrounding the cylinders usually constructed as part of engine block and head. Engine coolant flows through the water jacket and keeps the cylinder walls from over heating. The coolant is usually a water ethylene glycol mixture.

**Water pump :** Pump used to circulate engine coolant through the engine and radiator. It is usually mechanically run off the engine.

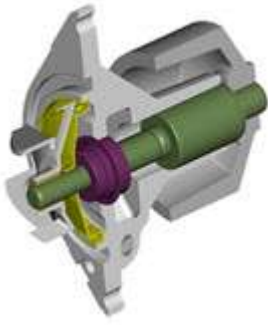

Crank mechanism is used to convert reciprocating motion to rotary motion and vice versa. It consists of following components.

- i) Crankcase
- ii) Crankshaft
- iii) Main bearings
- iv) Flywheel
- v) Vibration dumper
- vi) Crankcase breather

**Crankcase:** It is the part of the engine block which contains the rotating crankshaft and acts as engine oil reservoir as the oil pan is an integral part of the crankcase housing. Crankcase is also provided with engine breather known as crankcase breather to reduce air pressure build up on the backside of the pistons during power and intake strokes. This is also known as crankcase ventilation.



**Crankshaft :** Crankshaft is the engine component from where the reciprocating of the piston is taken out as work output in the form of rotary motion. The reciprocating motion of piston is transferred through the connecting rod. Crankshafts are provided with holes to provide lubrication to the moving components. Crankshafts are generally manufactured as one piece of forged heat treated alloy steel and are machined with a very high precision.



**Main bearings :** Main journals form the axis of the crankshaft and are supported in main bearings. These bearings are of split type and are replaceable. Bearings are made of very thin alloy lining applied on copper or steel backed surface to attain greater durability and heat dissipation.



**Flywheel :** The rear end of the crankshaft carries flywheel. It is the rotating mass connected to the crankshaft having large moment of inertia. The flywheel is provided to store energy and momentum that that keeps the engine rotating between power strokes and other engine strokes. In multiple cylinder engines, the size of flywheel is relatively c than the single cylinder engines.

**Vibration dumpers :** When engine runs continuously, due to rotational motion of the crankshaft and big end of the connecting rod, they are subjected to bend. To counter this side effect, counter weights are provided to run the engine smoothly. These are either made integral part of the crankshaft or attached separately to it. Counter weights known as vibration dumpers must be balanced carefully to eliminate undue vibration resulting from the weight of the offset cranks.

**Crankcase breather :** The crankcase breather is used to avoid build-up pressure in the sump and maintain normal pressure inside it. Any gas passing into the crankcase is expelled through the breather. The breather cap and the element should be cleaned periodically. The air full of dust could also get into engine through this breather cap and hence it should be maintained properly.

## LESSON 6

### VALVE MECHANISM AND VALVE TIMING DIAGRAM

#### ➤ Valve Mechanism

Engine valves are used in engines to allow air or air-fuel mixture to enter into the cylinder (through inlet valve) and also to push exhaust gases (through outlet valve) from the cylinder at a specific time during the engine cycle. To have complete contact between the valve and engine surface (head), an accurately faced surface is provided which is known as valve seat. For inlet valves, the seat surface is directly machined on the engine head and are also known as integral seats. However, special seat inserts are used for exhaust valves as these are continuously exposed high temperature and thermal stress.

The stem of the valve needs to move up and down without any deviation from its axis. Since, these stems are subjected to side thrust also, the valve guides are provided to maintain its alignment.

Sometimes, these guides are the direct holes in the engine block. However, separate valve guides have also been used as inserts which are cylindrical in shape. The clearance between the valve stem and guide is kept optimum/sufficient to maintain lubrication film around the stem surface.

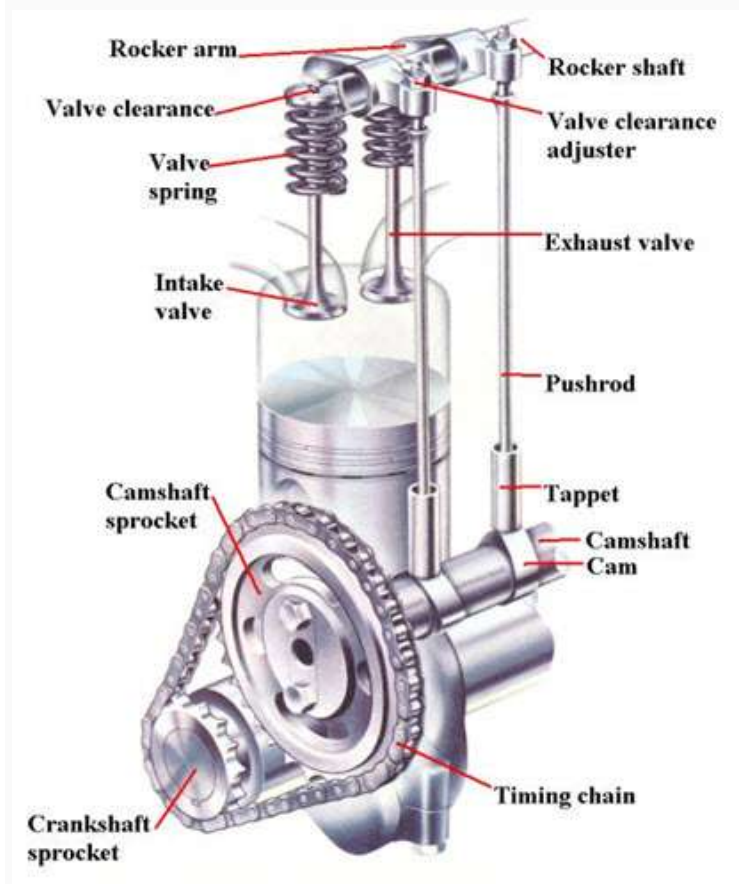

Valve spring (helical) are used to keep valve in regular contact with the tappet and the tappet with the cam. These valve springs should be fatigue resistant and are made up of high grade spring steel wire, hard-drawn steel or chrome-vanadium steel.

### Valve actuation

A complete mechanism is involved in actuating the inlet and exhaust valves (opening & closing) through the motion of different components come in valve train. A cam is used as a drive to actuate the valve and this cam rotates at half of the speed of crankshaft in a four stroke engine. Following are the various components of valve train.

- i) Camshaft
- ii) Tappet
- iii) Push rod
- iv) Rocker arm
- v) Valves

**Camshaft :** Camshaft is a shaft in which cams are provided as integral part of the shaft. Separate cam is provided for each valve (inlet and exhaust). Cam has its path profile having high spot known as nose and the lowest point termed as base. These two points nose and base correspond to fully opened and closing of valves respectively. The cam profile is provided to have smooth rise

(opening) and fall (closing) of valves. The cam is a rotating element which generates the reciprocating motion to the follower which is known as push rod in a plane at right angle to the cam axis. Cam shaft is also used to drive fuel pump. Camshaft is made up of forged alloy steel which is case hardened.

**Tappet :** This is also known as cam follower or valve lifter which follows the shape of the cam to provide reciprocating motion to the valves by converting angular/rotating motion of the cam shaft. The tappet is placed in between the cam and the push rod which helps in preventing the side thrust to be exerted from the cam on the push rod. Some clearance is provided between the cam and tappet to take care of thermal expansion and this clearance is known as valve lash.

**Push rod :** The reciprocating motion of the push rod actuates the rocker arm which moves in an arc about its pivot. Push rods are made of carbon-manganese steel.

**Rocker arm :** The rocker arm is used to convert the upward movement of push rod to the downward movement of the valve (opening up) and also the downward movement of pushrod to upward movement of valve (closing down). The rocker arm can be made of either hollow or solid material. The rocker arms are pivoted to rocker shaft which also provides lubrication

**Valves :** Although various types of valves are available but poppet valves are the most commonly used engines valves being used in engines these days. These poppet valves are also known as mushroom valves as its shape resembles to the mushroom having head and stem. Generally, inlet valves are larger in size to enhance the air intake and exhaust valves are made relatively harder than the inlet valves as these are exposed to hot exhaust gases always. Exhaust valves are made up of special material i.e austenitic steels and precipitation hardening steel which should have high strength to resist tensile loads, wear resistance due to heat, corrosion resistance, low coefficient of thermal expansion and high thermal conductivity. Since, the valve temperature reaches to several hundred ( $750^{\circ}\text{C}$ ), valve cooling is also essential for which valve stems are sometimes filled with sodium (which has high thermal conductivity).

### ➤ Valve Timing

Opening and closing of inlet and exhaust valves is a process which are timed to achieve maximum engine efficiency by completing the various strokes engine cycle at predetermined time intervals. Theoretically both the valves, inlet and exhaust should open at TDC and BDC respectively. Similarly, the exhaust valve should remain open till the piston reaches to TDC during the exhaust stroke and it should be closed fully at TDC. But in practice, due to inertia the valves can not be opened and closed instantaneously and it is not desired even as the intake of air/air-fuel mixture and exhaust of burnt gases are required to be completed. The periodic opening and closing of inlet and exhaust valves is known as valve timing.

The inlet valves is generally opened before  $10^{\circ}$  of TDC which is known as valve lead and closes almost  $46^{\circ}$  after BDC which refers to valve lag. Similarly, the exhaust valve is opened before  $46^{\circ}$  of BDC and closed after  $10^{\circ}$  of TDC. The condition when both the inlet and exhaust valves are open simultaneously is called valve overlap. The valves are opened and closed according to the valve timing diagram. The cam shaft which is run through timing gears rotates at half of the number of rotations per minute of the crankshaft. The valve mechanism is generally classified by the method of valve arrangement as either side valve or over head valves. The overhead valve arrangement is the most commonly used arrangement these days.

The opening of inlet valve is advanced to use the depression made by the outgoing gases and hence the fresh air is taken inside the cylinder. But, if the inlet valves are opened very advanced, it may make some of the exhaust gases to re-enter in the cylinder through the inlet manifold. Similarly, the

closer of the inlet valve is made later than the BDC when the piston has already started moving up for the compression stroke, this is done to achieve the maximum volumetric efficiency.

Ideally, the exhaust valve should be opened after the piston reaches BDC on completion of the power stroke, but the exhaust valve starts opening well before the piston reaches BDC. This makes the exhaust gases to escape from the cylinder with its own energy and hence reduces the work to be done during the exhaust stroke. The closure of exhaust valve is delayed to the piston reaches TDC making fully removal of burnt gases and creating partial vacuum inside. But, if the closure of exhaust valve is delayed more, it would result into loss of fresh air also through the exhaust valve. Thus the advantage of valve overlap is obtained to achieve maximum engine efficiency.

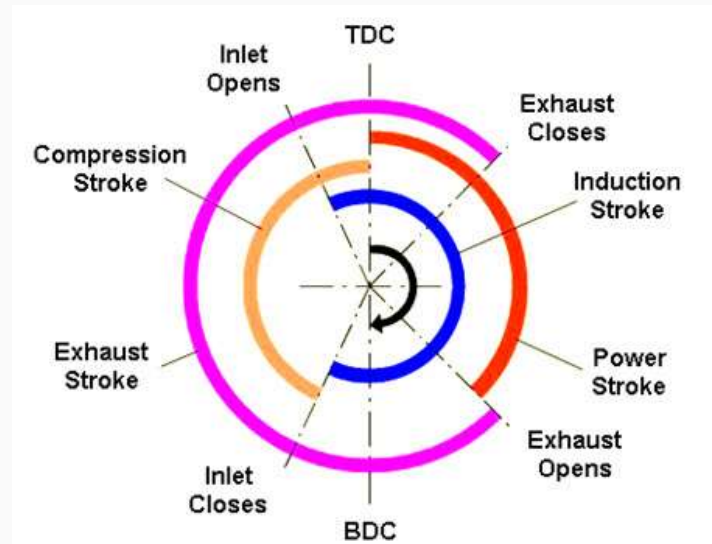

## LESSON 7

### FUEL & AIR SUPPLY SYSTEM

#### INTRODUCTION

Engine fuel supply system covers the quality and quantity of fuel, air and air fuel mixture flow and combustion aspects in efficient operation of an engine by performing following functions. The fuel system covers the travel of fuel from the fuel tank to injection of atomized fuel into the combustion chamber/cylinder where the burning of fuel takes place to generate mechanical work output. Various components like fuel tank, fuel feed pump, fuel pipes, fuel filters, fuel pump, high pressure pipes, injecting nozzles are the components of fuel line to be discussed in this module.

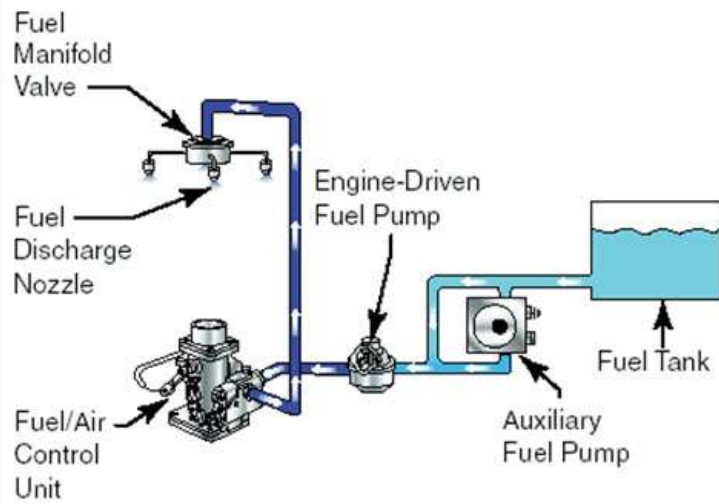

**Fuel storage :** Fuel tank is usually made up of metal or fibre sheet having anti rust and better heat and shock resistant properties. Fuel tank should prevent fuel to get contaminated with dust, water or any other foreign material. These impurities in the fuel can block the passage of fuel through the pump and nozzles which further stop the engine.



**Fuel Filtering :** Fuel filters (primary & secondary) are provided to remove the impurities (water or dust) from the fuel while flowing from tank to reach fuel injection pump. Primary filter is usually made of wire mesh and used for removing the coarse particles. It is attached to the fuel feed pump.



Further to remove the fine particles and abrasive material in the fuel, secondary filter is used which is made of fine pores and it is placed after the fuel feed pump. These smallest impurities are retained to protect the extremely sensitive parts like fuel pump and injectors to get damaged. These filters are generally made of two sections/stages in which first stage is made of cloth and second is of paper through which the fuel passes to leave impurities behind in the fuel line.

### **Air Cleaners**

Since the air fuel mixture is to be burnt in the combustion chamber of the cylinder, just like fuel being filtered, air should also be filtered and cleaned before entering into the cylinder. The dust particles in the air when mixed with oil act like abrasive material which deteriorates the cylinder walls or liners, pistons or rings and hence decrease the engine performance. The characteristics of an ideal air cleaner include high efficiency in dust removal from air, small restriction to the air flow, small and simplicity in design and easy to mount, clean and low in cost. The location of air cleaner on the vehicle affects cleaning efficiency and it is one of the most important design parameter to be kept in mind while designing and developing the product. The dust concentration is maximum near the engine and is least in the region exactly above the engine. Hence, the air cleaners are mounted directly above the engine housing. Since, tractors are to be operated in the fields where dust is always significantly high, periodic cleaning of air cleaner becomes very important and essential to have maximum and consistent engine efficiency.

### **Oil bath type air cleaner**

It consists of wire mesh element and oil reservoir at the bottom. The atmospheric air enters the air-cleaner through the windows at the top with a swirl action where some impurities are retained in the pre air cleaner chamber. The air passes through the air duct to the surface of oil bath and the air is reflected upward from the surface oil. The small impurities like dust and chaff etc. stick to the oil surface and are separated from the air. Then the air starts moving upward and passes through the mesh which further cleanse the air and oil drops in the air are separated while passing through this mesh. The left over impurities are also retained by the mesh and get settled in oil bath. These oil bath/bowl and pre cleaner chambers are to be cleaned periodically depending upon the dust conditions. The level of oil is to be maintained at a specific level, because the oil above the desired



level results in restricting the air flow and might result in carrying/moving the oil with air reaching engine cylinders. This may lead to increase in sudden increase in speed and sometimes can cause damage to the engine components also.



### **Dry air cleaner**

This type of air cleaner consists of a paper filter element with a row of plastic fins around it. As the air from the atmosphere enters the cleaner, the plastic fins give it a high rotational speed between the casing and the filter element. This causes impurities to separate out from air due to centrifugal action, which are thrown out to the casing walls from these flow down. Air without these dust particles then passes through the paper element, which removes any further impurities and clean air then goes to the engine.



### ➤ Turbochargers & Superchargers

**Turbocharger :** It is a centrifugal compressor driven by turbine which is run by exhaust gases to compress incoming air into the engine. With increased pressure, the weight or amount of fuel entering the same space inside the engine is increased. In this way, the burning of fuel is more efficient inside the engine chamber and it eventually results in greater performance of the vehicle from the same displacement of engine without need of a larger displacement engine.

Exhaust gases contain a significant portion i.e around 30% of heat energy being generated due to burning of fuel. In turbocharger, exhaust gasses are used to drive a compressor which has following advantages to be used in diesel engines.

- i) Engine output power is increased for a given engine displacement and has better Power/Weight ratio
- ii) Engine torque characteristics are enhanced
- iii) Better engine performance at higher altitudes
- iv) Better fuel economy and exhaust gas emission

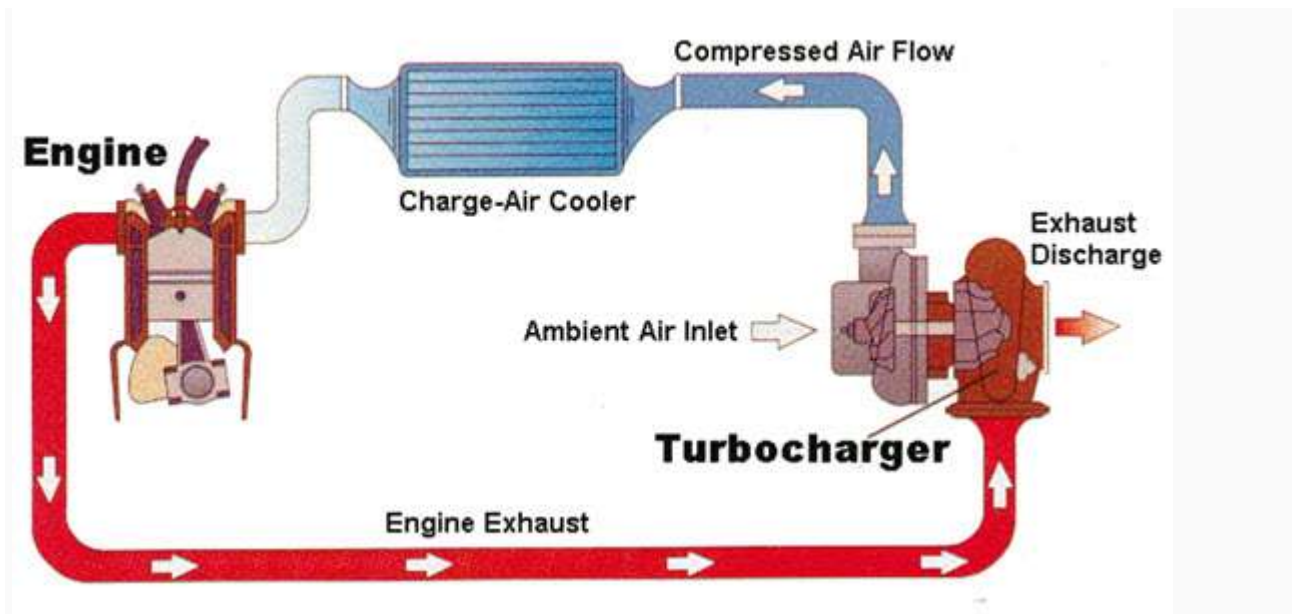

**Superchargers:** The device (compressor) powered by crankshaft used to compress incoming air of the engine is called supercharger. Supercharger is used to increase the volumetric efficiency of an engine by feeding both air and fuel at high pressure. The supercharger is driven directly by the engine through belts, the response of the same is instantaneous and a sudden increase in power can be obtained. Generally, in the natural aspirated engines, the charge is sucked in the cylinder by the vacuum created due to downward motion of the piston in the cylinder. With supercharger, the charge is induced with pressure which increases the density of the charge and hence the weight of charge per stroke is increased. As the weight of charge is increased, the power output also increase upto extent of 40% with supercharging.

At higher altitude, since the air gets thinner, the need of supercharger increases as it compensates the air intake by making relatively denser/heavier air into the cylinder during the suction stroke. Since, the supercharger increases the pressure, engine must be able to sustain the higher forces and also the fuel being used to have better anti-knock properties. However, in petrol engines when density of fuel is increased keeping the fuel of same octane number, the compression ratio is to be decreased to avoid detonation. But, with decrease in compression ratio, the thermal efficiency also decreases which is not preferred. Following are the three types of superchargers are being used.

- i) Centrifugal supercharger
- ii) Vane supercharger
- iii) Root's supercharger

## Roots Supercharger

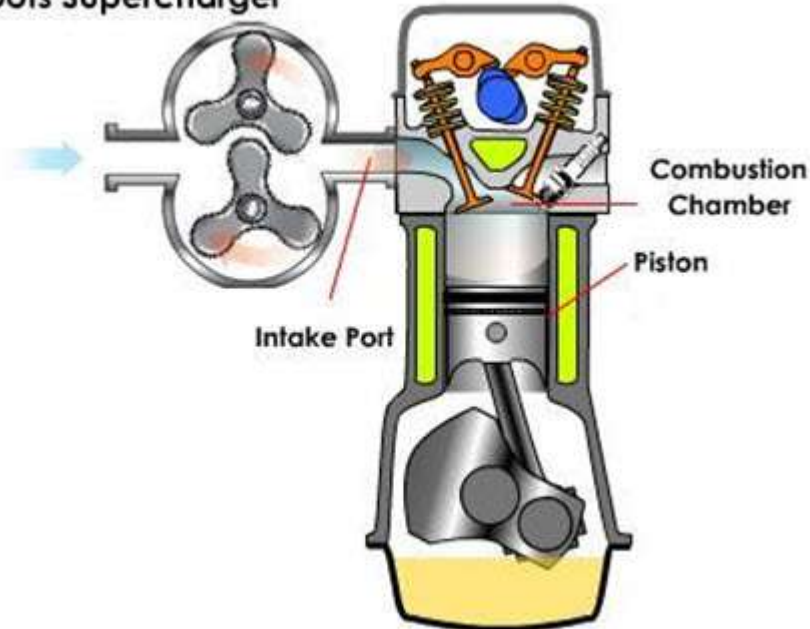

**Centrifugal supercharger :** This is one of the most commonly used supercharger which is driven by belt and pulley. The air fuel mixture enters into the impeller of the supercharger where this mixture is supercharged with pressure using the kinetic energy. The impeller runs at sufficiently high speed of around 80000 rpm. The impellers are made of special material like alloy steel which can with stand the high stress being generated due to such a high speed of impellers.

**Vane supercharger :** The rotating drum of supercharger is mounted with number of vanes which are made of laminates of linen or tufnol as these material have low friction, low coefficient of thermal expansion and also run without making any noise. As the drum rotates, the space between the body and drum decreases from inlet to outlet which decreases the volume and increase the pressure at outlet.

**Root's supercharger :** This consist of two rotors of epicycloid shape which are connected with each other by gear of same size to make these rotors run at same speed to generate pressure in the mixture coming out from the outlet just like it happens in gear type pumps.

Although turbochargers are similar to superchargers as far as the purpose of their usage is concerned. Both are used for increasing the density of air intake in the engine. But the major functional difference lies in their mode of driving mechanism. Turbochargers are driven by the exhaust gasses whereas the superchargers are directly driven by the bet pulley mechanism by taking a portion of power out of an engine. Although, superchargers are easier to install, but it costs more.

### ➤ Fuel Injection Pump & Nozzles

## Fuel Delivery & Injection

It involves the flow of fuel from fuel tank to fuel nozzles for injecting the desired quantity of fuel with required pressure in the combustion chamber. Fuel travels fuel pipes from fuel tank to fuel feed pump through primary filter under gravity and then with the help of fuel injection pump, it further reaches to injecting nozzles with pressure through high pressure pipes. Engine speed tends to overshoot to hazardous values on reduction of load and also to very low speed (almost on the stage of engine halt) on increase in sudden and unexpected load application. To avoid such

conditions, the engine speed is controlled by regulating the fuel supply by using engine governor which has been discussed in detail in lecture no. 22 & 23.

### **Fuel feed pump**

The fuel comes from the fuel tank to the fuel feed pump which makes it to reach fuel injection pump after traveling through primary

and secondary fuel filters. Sometimes this feed pump is also known as transfer pump or lift pump. Various types of feed pumps are used for the engines depending upon the application for which they are to be used. Fuel feed pumps can be of following types.

- Diaphragm type



- Gear type
- Vane type
- Plunger type

The hand priming pump is meant to bleed the fuel supply system when required. If the engine has not been working for a considerable period, the fuel can be transferred rapidly from the fuel tank to the fuel injection by hand-priming pump.

### **Fuel injection**

The fuel injection system is required to inject the atomized fuel coming from fuel injection pump at high pressure to inject into cylinders/combustion chamber in exact and desired amount of fuel at desired time. Usually solid injection system is the most common system being used these days for injecting the liquid fuel which has been further classified into following two types.

- Common rail fuel injection system
- Individual pump fuel injection system.

### **Common rail fuel injection system**

Common rail fuel injection system has single injection pump with individual injector which is also known as unit injector on each cylinder injector. These individual injectors are operated by rocker arms and springs connected with control racks through the linkage to control the fuel injection in all cylinders simultaneously.

## **Individual pump fuel injection system**

Plunger type or the diaphragm type in-line fuel feed pumps are used to inject fuel in the cylinders. The fuel travels from fuel tank with the help of fuel feed pump being driven by injection pump camshaft. Hand-priming lever is provided in the fuel feed pump to initiate the fuel flow and also to blow the air out from pump. The fuel then travels through filters and injection pump to reach engine cylinders in the desired quantity according to the firing order.

### **16.4 Fuel injection pump**



The fuel injection pump is used to deliver an accurate and metered quantity of fuel under high pressure, at the correct instant and in the correct sequence, to the injector fitted on each engine cylinder. The injection pressures generally varies in the range from 7 to 30 MP and can be exceptional high as 200 MPa. The fuel injection pump is driven by timing gears and is controlled by the operator through hand or foot accelerator in a tractor. These fuel injection pumps are designed and manufactured with high precision as these are used for metering very low volume of fuel and very high frequency of injection

The fuel injection pumps are generally of jerk pump type. However, in many cases, distributor type pumps are also used. Both of these will be discussed here.

#### **Inline type fuel injection pump**

Inline type fuel injection pumps are also known as jerk type fuel pumps. These can be used for both single cylinder and multi-cylinder engines. Mainly it consists of spring loaded delivery valve, the plunger, the control sleeve and the control rack. The plunger contains a helix at its upper end which is operated by cam and tappet to controls the quantity of fuel to be injected.

In multi-cylinder engines, multiple pump assemblies, one for each cylinder, are assembled into one unit to give a compact construction. Fuel comes out from the injection pump with such a high pressure that specially designed and manufactured high pressure delivery lines are used to transfer this pressurized fuel to different fuel injectors mounted on each cylinders. In-line pumps are consist of pump housing, governor housing, camshaft-tappet assemblies and the pumping elements. The function of the camshaft is to generate plunger movement for each pump in the prescribed firing order and at the correct instant. The pump housing is made of aluminum alloy casting which contains camshaft-tappet assemblies, control mechanism and governor and the pumping head.



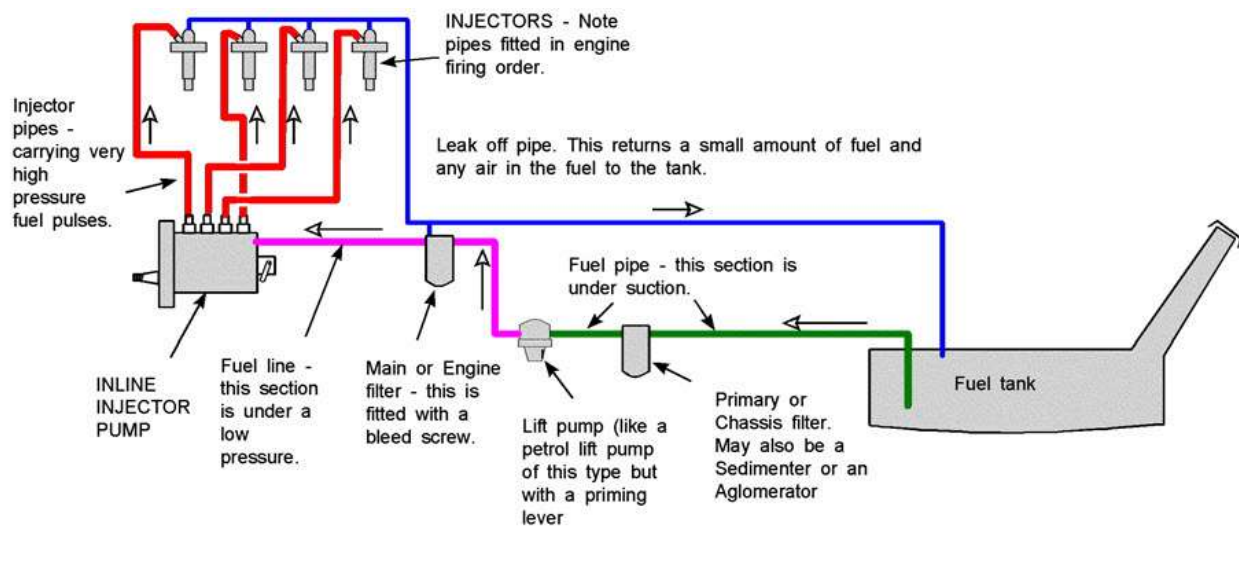

### Rotary type fuel injection pump

These rotary type fuel injection pumps are also known as distributor pumps in which the fuel is distributed to each cylinder by means of a rotor. The rotor has a set of radial holes (suction and delivery ports) equal to the number of engine cylinders. Each of the delivery ports is connected to the high pressure delivery lines leading to injectors mounted on the each cylinder in multi-cylinder engines. As the rotor revolves, the suction ports align with the intake metering port one by one, while the distribution port aligns with the delivery ports in turn. Internal cam ring is used to control the fuel injection timing in these rotary pumps. With the increase in engine speed, the fuel feed pump delivery pressure increases which moves the cam in an advance direction to provide more timing. Rotary fuel injection pumps are compact, small in size and have less weight. Since there is a single rotor being used for delivering fuels to the multiple cylinders through individual high pressure pipes, the equal quantity of fuel is delivered which helps in even combustion of fuel in all the cylinders as per the firing order and generating consistent power strokes.

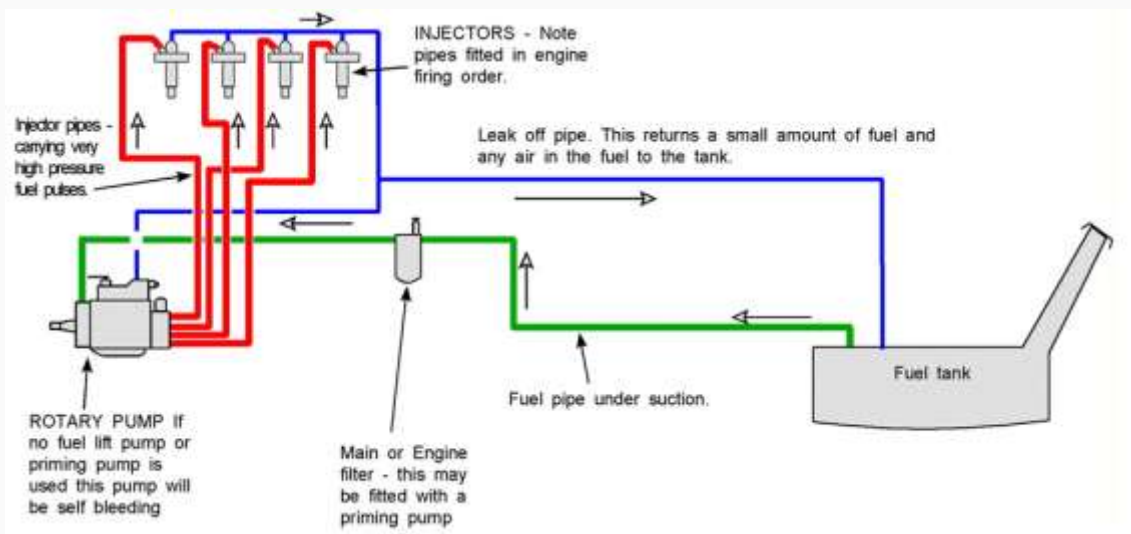

### Fuel nozzles

These are also known as injectors, atomizers or fuel valves. Nozzles are used to inject the fuel in the combustion chamber/cylinder in a desired atomized form and in exact quantity on exact time. Generally, replaceable nozzles are provided with screw caps to ease the change of nozzle

whenever required. A spring-loaded spindle is used to keep the nozzle valve pressed against its seat in the nozzle body. As the fuel is supplied by fuel injection pump with sufficient pressure to lift the nozzle valve against the spring force, then a spray of atomized fuel is fed into the combustion chamber. The fuel spray continues till the nozzle valve closes back on its seat. The pressure at which the nozzle valve opens is adjusted by a screw provided at the top of nozzle. Following are the two types of nozzles being used in engines these days.

- Hole type nozzles

- Pintle type nozzles

Hole type nozzles are the most commonly used in engines having open type combustion chambers, whereas pintle type nozzles are common in engines with pre-combustion chambers and some special swirl chambers. The pintle type nozzles carry an extension, which produces a hollow cone type spray. Such nozzles have the advantage of being self-cleaning. The opening pressure of hole type nozzles varies from 17 to 34 MPa, whereas that of pintle type nozzles varies from 7 to 15 MPa.

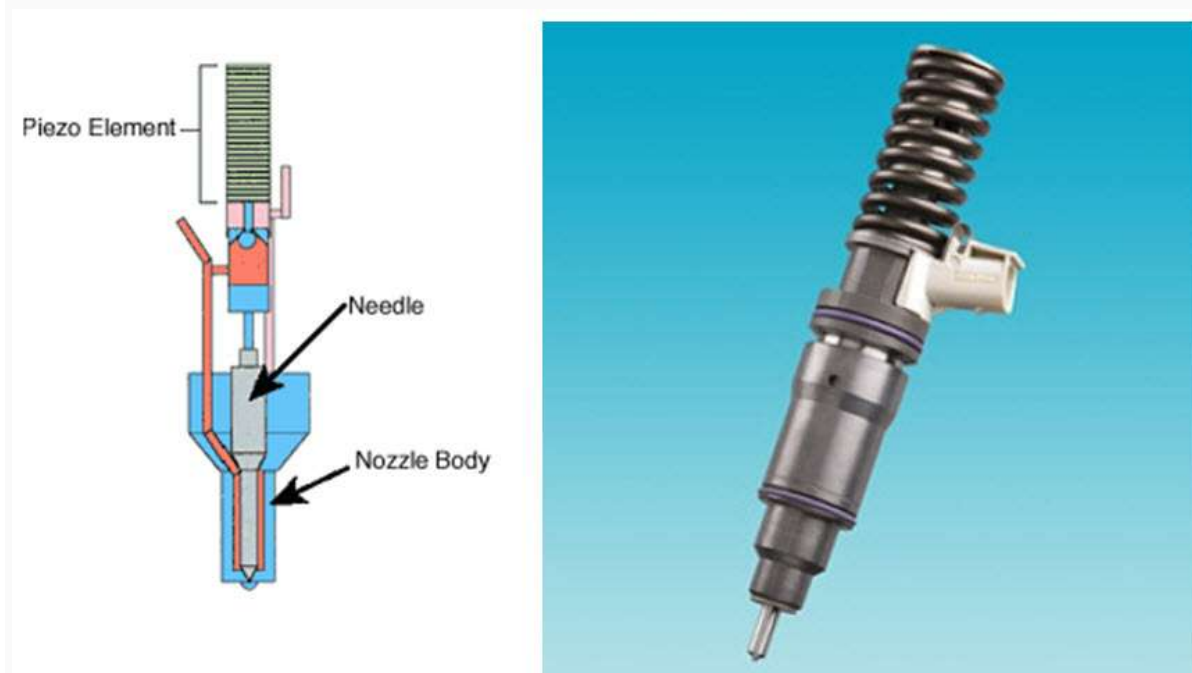

### ➤ Carburetor

Carburetor is the device which works on Bernoulli's Principle and is used in petrol engines to controls the amount of atomized fuel and air in the air fuel mixture to be supplied to engine combustion chamber. Carburetor is provided with the throat in which the air stream flows. The velocity of air is more in the throat as compared to velocity at the entrance and this high velocity reduces the pressure inside the throat which makes the fuel to enter in the throat due to pressure difference and gets mixed with the air stream. Under all conditions, the engine carburetor must perform the following:

- Regulate the airflow in the engine
- Supply the required amount of fuel to maintain the level of fuel/air mixture
- Prepare the exact fuel and air mixture

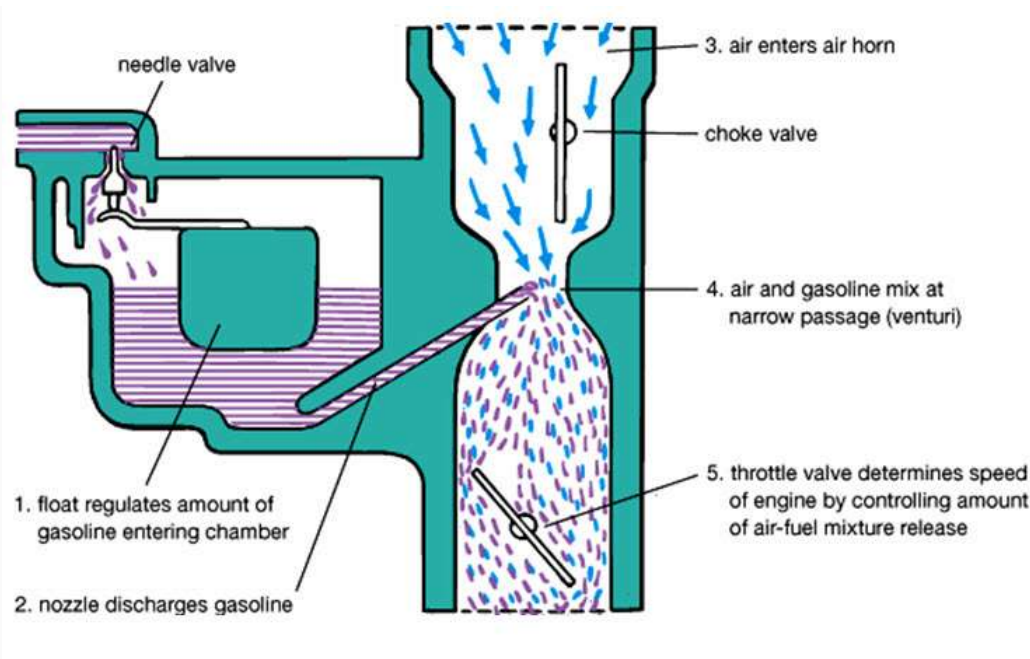

Following are the components of carburetor :

- Float chamber and float
- Venturi
- Nozzle
- Throttle valve
- Fuel jet
- Choke

**Float Chamber and float :** Special purpose light weight brass metal is used in the float chamber to maintain the constant level fuel in the float chamber. The float is attached to the stopper like mechanism to allow and restrict the entry of fuel in the chamber as it moves down and up. The metallic floats have tendency to get damaged and leak from the joints. So to avoid this, plastic or rubber material is used for manufacturing float. The level of fuel in the float chamber is maintained lower than the nozzle outlet.

**Venturi :** The fuel from the nozzle flows into the venturi, which is simply a restriction in the air passage. Venturi is the area where this passage area in the direction of air flow is minimum. As the passage for area decreases, it increases the air velocity and hence decreases the air pressure. Due to this depression in the pressure, the fuel comes out from the nozzle and gets mixed with the air and converted into fuel vapours. Then, this air fuel mixture is entered into the engine cylinder through inlet manifold. The quantity of fuel entering into the engine cylinder depends upon the jet size, float level and venture vacuum.

**Nozzle :** It is used in the venturi to discharge the fuel and get mixed with the air stream. The nozzle outlet is place above the level fuel in the float chamber to avoid spilling of fuel from the nozzle when vehicle is running on slope and highly cambered roads.

**Throttle valve :** It is used to control the quantity of flow of air fuel mixture. Throttle valve is attached to the accelerator pedal through lever mechanism. Butterfly or cylindrical valves are used

but butterfly type is most commonly used valve for controlling the air fuel mixture. Butterfly type is simply a disc type mechanism hinged at the centre. Although it is easy use and operate, but it restricts the flow even when it is fully opened. No suction is applied to the nozzle when the throttle valve is fully closed.

**Fuel jet :** The flow of fuel from the float chamber to the venture through the nozzle is metered by fuel jet. It regulates the fuel supply. Fuel jets are made of special brass material and should have anti corrosive material. The engine idle speed and corresponding idling mixture is adjusted with the help of stop screw provided on the top of jet. Idle speed of an engine is adjusted by stop screw at the point where engine runs smoothly on the slowest speed at no load. Main jet adjustments are done after the engine is warmed up and put on load. When engine runs at full throttle, the main jet is turned until the full power is regained and engine runs smoothly. The jet screw is rotated further (to almost half turn more) to avoid engine stalling due to load variations.

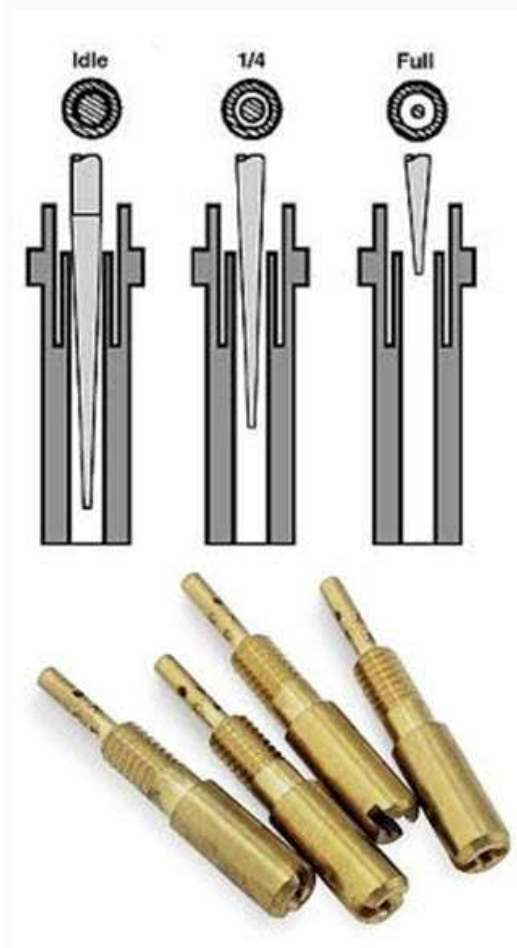

**Choke :** It is a butterfly valve operated by hand lever or sometimes automatic to restrict the air flow and hence increasing the proportion fuel in air fuel mixture. The choke is generally applied for initial starting purposes. The choke is to be opened immediately when the engine gets started otherwise the flooded fuel would result into engine stall. Carburetor can be of following three types on the basis of direction of air-fuel mixture is supplied :

- i) Up-Drought
- ii) Down-Drought
- iii) Horizontal

Out of above mentioned types of carburetors, down-draught is the most commonly used type due to following advantages :

- i) Fuel flows due to gravity which helps the engine under load to run smoothly at lower speed
- ii) Volumetric efficiency can be enhanced and it is easy to access

## **LESSON 8**

### **FUEL PROPERTIES**

Engine needs to run on fuel of high quality to produce maximum work output. Several fuel properties have been identified and defined as following.

- i) Heat value or Calorific value
- ii) Specific gravity
- iii) Volatility
- iv) Flash point
- v) Fire point
- vi) Pour point
- vii) Viscosity
- viii) Octane number
- ix) Cetane number
- x) Carbon residue
- xi) Sulphur content
- xii) Gum content

#### **Heat value or Calorific value**

It is the indicative of heat energy being produced by the fuel when it is burnt inside the cylinder/combustion chamber of an engine. It is expressed in J/kg of fuel and is measured in the device which is known as calorimeter. The impurities in the fuel leads to decrease in its heat value.

#### **Specific gravity**

It is expressed as the ratio of the density of fuel to the density of water. The specific gravity affects the fuel atomization in the nozzles and spray penetration/injection in the engine cylinder/combustion chamber. Fuels which are relatively heavier have usually greater heat value. The specific gravity is measured by the hydrometer.

#### **Volatility**

It is the property of the fuel to get converted into vapours on burning at a specific temperature. The volatility is measured by means of distillation. In diesel fuel, volatility is indicated by 90%

distillation temperature (temperature at which 90% of the fuel is distilled off). Lower volatility in fuels leads to increase in carbon deposits, smoke content and also wear of engine components.

### **Flash point**

It is the temperature at which the fuel must be heated to get flammable vapours and is driven off to ignite when brought into contact with the flame.

### **Fire point**

It is the higher temperature at which the vapours will continue to burn after being ignited. Generally, the fire point is  $10^0$  to  $21^0$  C higher than the flash point and it is the indicator of fire hazards. The lower the flash point, the greater is the fire hazard. In general, the flash point should be high enough to avoid producing flammable vapours.

### **Pour point**

It is the temperature at which the fuel becomes insoluble to prevent flow under specified conditions. In cold weather conditions, this becomes very important parameter as wax crystals start forming even when temperature is slightly over the pour point. A higher pour point implies that in cold weather the fuel will not flow easily through the filters and fuel system and also the atomization/spray characteristics are affected.

### **Viscosity**

It is the property of fluid/liquid that resists the force which makes the liquid/fluid to flow. It is measured by the instrument known as viscometer in which the time required by certain volume of fluid to flow is measured under stated conditions. It affects the spray pattern of fuel in the combustion chamber. Low viscosity produces a fine mist, whereas high viscosity leads to coarse atomization.

### **Octane number**

It is a standard used for determining the knock characteristics of fuels (petrol) and it refers to the percentage by volume of iso-octane ( $C_8H_{18}$ ) in a mixture of iso-octane and normal heptane ( $C_7H_{16}$ ). Fuel knock is prevented by the fuel's ability not to self ignite in the combustion process.

### **Cetane number**

It is the measure of fuel property in which it is measured that how easily and fast the fuel (diesel) is ignited when reaches into the engine combustion chamber/cylinder. A cetane number rating is obtained by comparing the fuel with cetane, a colourless liquid hydrocarbon, which has excellent ignition qualities and is rated as 100. The percentage of cetane in a mixture of cetane ( $C_{16}H_{34}$ ) and  $\alpha$  (alpha) methyl naphthalene ( $C_{11}H_{16}$ ) is called cetane number. The higher the cetane number the shorter the lag between the instant fuel enters the combustion chamber and the instant it begins to burn. The commercial diesel fuels have got cetane varying from 30 to 60.

### **Carbon residue**

Carbon residue refers to matter left after combustion is an indication of the amount of combustion chamber deposits when the fuel is burnt in the engine combustion chamber/cylinder. It varies from 0.15 to 0.35% on weight basis and its permissible limit depends upon the engine characteristics. This property is more critical in small high speed engines than in large, low speed engines.



## **Sulphur content**

The presence of sulphur in high quantity in the fuel is not desirable as it increases the wear of engine components specifically, the piston rings and the cylinder walls. It also causes the formation of hard coatings on the piston and oil sludge in the engine crankcase. The sulphur in fuel after burning combines with the water to form corrosive acids which further damages the finished surfaces. Sulphur content varies from 0.5 to 2% on weight basis.

## **Gum content**

Gum in the fuels is formed by the polymerization of some unsaturated hydrocarbons. To have good quality of fuel, the gum content should be minimum.

## **Engine Detonation**

Engine detonation is an engine refers to inappropriate combustion of fuel in the combustion chamber/cylinder of the engine. Either the compressed air fuel mixture is burnt in the cylinders with help of a spark (in SI petrol engines) or the air alone is compressed during the compression stroke and fuel is injected and burnt due to compression ( in CI diesel engines). To get maximum power from the engine it is required that proper of air fuel mixture or fuel is supplied to the engine and ignited at proper time. Sometimes, where preignition of fuel can happen in the engines, it is also observed that whole of the fuel or air fuel mixture is not burnt at once. Due to this, a pressure wave is set up in the combustion chamber which travels to and fro and hits to the cylinder walls. This disturbance in the cylinder forces the walls at the frequency of gases which produces a very peculiar sound which is known as engine detonation or knocking.

Engine detonation can also be illustrated as it can also occur due to sudden and instantaneous ignition of the unburnt charge when the temperature and pressure is so high and sufficient to ignite the fuel or air fuel mixture. The factors affecting engine detonation can be classified as follows :

- i) Engine factors
- ii) Air, Fuel and Air-Fuel mixture factors

## **Engine factors**

There are engine characteristics which can affect engine detonation include :

- **Compression ratio** : Engine detonation increases with increase in compression ratio as it increases the gas temperature and pressure thus lowering the reaction time for charge to get ignited. Every engine is designed for a particular maximum compression ratio and any compression ratio beyond this, causes engine detonation.
- **Engine size** : Engine detonation increases with increase in cylinder size (bore).
- **Spark advance** : Retarded spark helps in lowering the detonation whereas over-advance in spark leads to more detonation as pressure gets higher than the normal maximum pressure.
- **Design of combustion chamber** : The design which produces more turbulence in the combustion chamber, it helps in rapid combustion of the charge and hence decrease the chances to knock or detonate.
- **Defective cooling system** : If engine cooling system is not working properly due to fault in engine thermostat, water pump etc., it can also increase the engine detonation.

- **Engine speed** : At higher engine speeds which may also lead to fall in volumetric efficiency, the engine detonation is decreased.

- **Valve timing** : As the valve timing increases the volumetric efficiency which increases the air-fuel mixture intake and increase the cylinder pressure, the tendency to engine detonation is also increased.

### **Air, Fuel and Air-Fuel Mixture factors**

It has been observed that charge characteristics mentioned below can also be significant factors which can cause engine detonation.

- Octane number

### **Effects of detonation**

The main effects of detonation are:

1. Inefficient combustion.
2. Loss power.
3. Local overheating.
4. Mechanical engine failure.

### **Prevention of Detonation**

The different methods used for the prevention of detonation are:

1. Anti-knock agents.
2. Cooling of the charge.
3. Reducing the time factor.

## **LESSON 9**

### **NEED OF GOVERNOR : FUNCTION AND WORKING PRINCIPLE**

#### **Need**

In petrol engines, the carburetor controls both air and fuel delivery at various speed and load conditions. However, in diesel engines, governor is the device used to control the engine speed. Governor regulates the engine speed by varying the fuel flow as per the load conditions. Engine speed tends to overshoot to hazardous values on reduction of load and also to very low speed (almost on the stage of engine halt) on increase in sudden and unexpected load application. To avoid such conditions, the engine speed is controlled by regulating the fuel supply by using engine governor. All injection pumps operate in conjunction with the governor. Generally, when the engine speed increases, the air intake decreases and hence results in more injection of fuel. On the other hand, at idling speed (no load conditions) or when the engine speed is relatively low, the fuel supply is also minimum. A governor is, therefore, a necessity to control the fuel injected to ensure optimum conditions at all speeds and loads within the range specified. A governor capable of holding any speed between idling and maximum speed is called variable speed governor.

## Working principle

The basic principle of working of governor is that the governor spring and flyweights are so selected that at any designed engine speed centrifugal force and spring force are in equilibrium. If the speed increases, the increasing centrifugal force of the flyweights acts through the system of levers to reduce the delivery of fuel and when the speed decrease, the control rod moves to step up the fuel delivery rate to increase the speed to desired level. The governor maintains all speeds automatically including idling and minimum speed. Governors are often included in the design of the fuel injection pump. The diesel engine governors should have following certain qualities or characteristics.

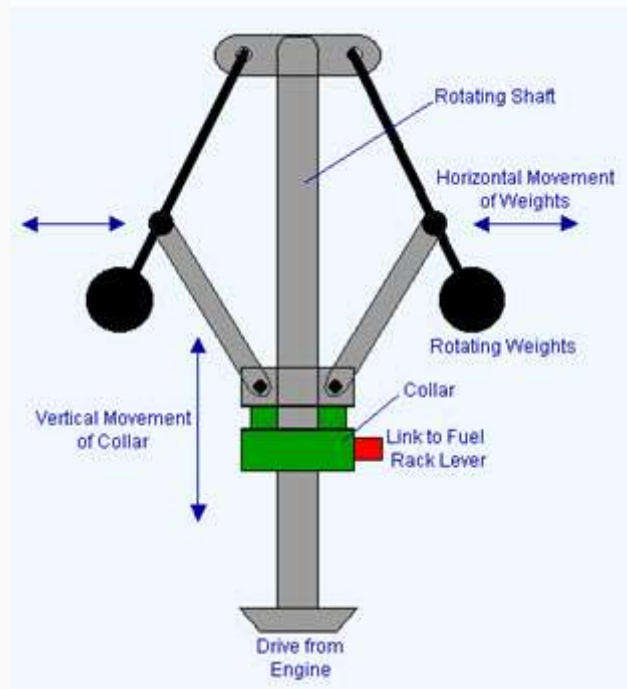

**Isochrones :** It should maintain engine speed at constant value regardless of the load.

**Stability :** Governor should maintain the desired speed without variation. If the governor is not stable, the speed will swing back and forth around the desired value which is known as hunting. A governor with a high degree of precision or stability is known as a “dead deal” governor.

The speed variation from no load to full load is known as “steady state regulation” or speed drop or RPM (revolution per minute) drop.

$$\text{Speed drop} = (S1 - S2)/S2 * 100$$

Where, S1 = No load speed

S2 = Rated full load speed

Similarly, to determine the sensitivity of governor, the degree of unbalance is evaluated at maximum speed.

$$\text{Percent of unbalance} : (S1 - S2)/S3 * 100$$

Where, S3 =  $(S1+S2)/2$

## ➤ Types of Governor

## Need

Governor is the device used to control the speed in engines. It is observed that when load is applied on the engine, the speed tends to decrease which is known as rpm drop also, to compensate the speed, governor is used in all stationary or mobile engines which run on either single speed or variable speeds. In general, following are the two operating systems being used in engines governors.

i) Hit and Miss system

ii) Throttle system

In hit and miss system, the frequency of cycles for fuel supply is controlled in the fuel system. Whereas, in throttle system, the frequency remains the same but the quantity of fuel is being controlled as per the engine requirements. Throttle system is the most commonly governing system being used in modern engines these days. The extent of throttle opening controls the fuel supply and hence the engine speed.

Although, the governor is used to maintain the constant engine speed, but still some variation in engine speed can be observed at no load and maximum load. This variation can be expressed in terms of Governor Regulation (%).

$$\text{Governor Regulation} = \frac{S_0 + S_1}{2(S_0 - S_1)} * 100$$

Where,  $S_0$  = No Load speed

$S_1$  = Maximum Load speed

The governors may be further classified as:

- i. Centrifugal/Mechanical governor
- ii. Pneumatic governor
- iii. Hydraulic governor

## Mechanical governor

The centrifugal/mechanical governor is most commonly used governor in tractors. Two spring-loaded centrifugal weights are mounted on the governor shaft having sliding collar which further actuates the throttle and the fuel supply. As the engine speed increases, the weights fly apart with the centrifugal force against the spring tension to actuate fuel injection pump to reduce the amount of fuel delivered and hence decreases the engine speed. Similarly, the fuel supply is increased by the governor when the engine speed tends to decrease.

## Pneumatic governor

A pneumatic governor consists of venturi unit and diaphragm unit which are connected by a vacuum pump. The venturi unit leads to the engine inlet manifold and the diaphragm unit is connected with the fuel injection pump. The position of the butterfly valve in the venturi unit is controlled by the accelerator pedal to control the amount of vacuum from the inlet manifold, to actuate the fuel pump through diaphragm unit and hence the amount of fuel injected.

## Hydraulic governor

A hydraulic governor works on the principle of pressure change and receives the oil from the engine lubricating system which further act as controlling force to control the fuel supply and hence the engine speed. The loss of oil pressure cuts the supply of oil to the governor and cause the governor to shut down the engine.

## LESSON 10

### ENGINE COOLING SYSTEM

#### Need

Engine is the device which converts heat energy generated from the combustion of fuel into useful mechanical work. Around 25% of whole heat energy generated from the fuel is utilized for generating the desired output. The rest of heat is either released in the form of exhaust gases or is absorbed by the engine itself. This absorbed heat by the engine is required to be dissipated through engine cooling system otherwise engine will become overheated and result in burning of lubricant which further causes the engine seizure and damage to the engine components. Following is the distribution of heat loss in engine operation.

- Loss of heat through the cylinder walls/liners : 30%
- Loss of heat through exhaust gases : 35%
- Loss of heat in friction : 10%

Keeping in view the essential requirement of maintaining optimum operating temperature of the engine a suitable cooling system is required. However, the cooling beyond the desired limit, results into decrease in the engine efficiency because of the following reasons.

- (i) Decrease in the thermal efficiency due to loss of heat
- (ii) Decrease in the combustion efficiency due to less vaporization of the fuel
- (iii) Decrease in mechanical efficiency due to increase in piston friction as the viscosity of lubricant increases with low temperature

The overheating of an engine is considered to be as serious and undesirable as over cooling. So, it is desired that the temperature of cooling system is to be maintained in the optimum operating temperature range ( 71<sup>0</sup> to 82<sup>0</sup>C for petrol engines and 88<sup>0</sup> to 90<sup>0</sup>C in diesel engines) to do the following ;

1. Maintain optimum lubrication between the moving components of an engine
2. Minimise the loss of power due to detonation
3. Avoids burning of oil with fuel

Generally there are two types of cooling systems used in an engine;

1. Air cooling system
2. Water cooling system

#### ➤ **Methods of cooling system & components**

- **Air cooling system**



An air blower or fan is used in the tractors having air cooled engines to circulate the air for dissipating the heat from the engine surface, cylinder in particular. Special baffles/fins are used to direct the air to reach the desired heated component and to avoid any hot spot. Size and spacing of the fins depend upon the amount to be removed, temperature of air, speed of air, material of fins and spacing between the fins and cylinder size. Generally, large number of short fins are considered to be better than small number of large fins. For an effective cooling the surface area of the metal in contact with the air is to be increased. Higher pressure of air is required when the spacing between the fins is reduced. Copper and steel alloys have also been used to improve the rate of heat transfer due to their better heat conductivity. Air cooled engines are comparatively lighter, easier to warm up than the water cooled engines. Air cooled engines can be used in extreme weather conditions where water may get frozen.

- **Water cooling system**

In water cooling system, water jackets are provided around the engine cylinder or liners. The circulating water in these jackets absorbs the heat from the cylinder surface and then heated water is cooled by the air passing in the radiator. The water cooling system consists of water jackets, water pump, radiator, thermostat valve, fan, belt and pulley etc. Although, water is the most commonly used cooling agent whereas, special coolants having better and desired properties like corrosion free, higher boiling point etc. are also available in the market and recommended also for obtaining and maintaining higher engine efficiency.



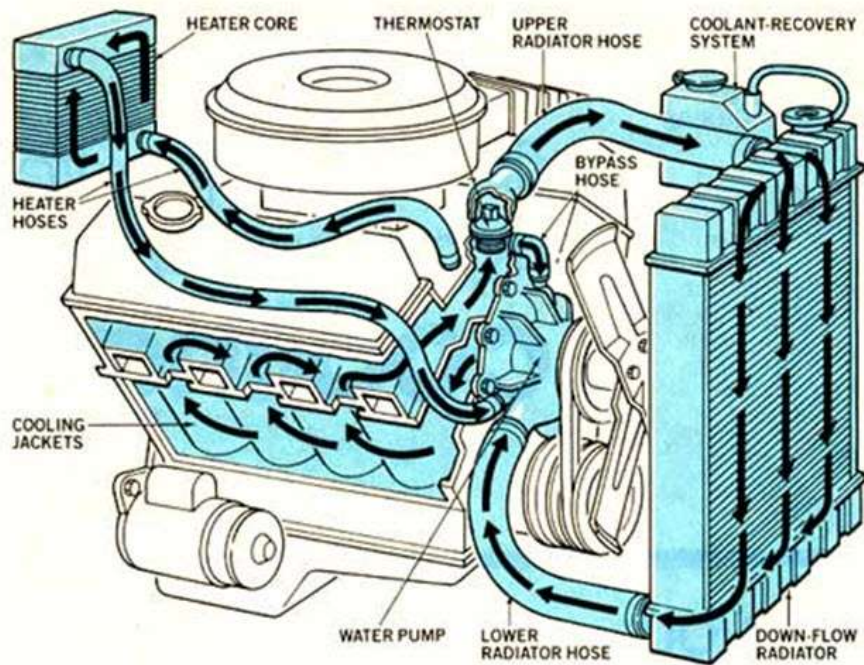

The water is made to circulate in the water jackets continuously with desired pressure and speed with the help of water pump driven by belt. Generally, water pumps are of centrifugal type and consist of water inlet and outlet with impeller which makes the water to come out from the pump outlet by a centrifugal force. The pump inlet is connected with radiator at bottom to draw the coolant/water from the radiator. When the engine is cooled, the thermostat valve remains open and same water/coolant is being circulated through the water jackets. By the time, water/coolant gets heated, the thermostat valve is opened to make water pass through the radiator to dissipate heat by coming intact with the air passing through the radiator. The radiator is located in the front of tractor/vehicle and it consists of water/coolant tank, tubes and pressure cap on the tube. This pressure cap is used to prevent water evaporation and increase the pressure with in the cooling system. The temperature difference between the air outside and water inside the radiator is high, and the heat is dissipated more quickly from water to the air. The air is generated with help of fan and also by the forward movement of the tractor.

Generally, engine operates efficiently in the temperature range of  $80^{\circ}\text{C}$  to  $90^{\circ}\text{C}$  and it always desired that the engine temperature should reach to this temperature as early as possible in cool weather conditions and remain in this temperature range only under excessive hot weather conditions. The thermostat is designed to maintain this temperature range by regulating the temperature of water/coolant circulating in the water jackets.

Proper maintenance schedules are to be followed to make these engine cooling system run properly to ensure desired engine efficiency and fuel economy. Running the engine at low temperature results into loss of fuel as unburnt fuel, dilution of lubricating oil and running the engine at high temperature causes wearing of engine parts and complete seizure.

## LESSON 11

### LUBRICATION SYSTEM

#### Need

Engine lubrication is required in an engine to do the following for running the engine at its maximum efficiency.

- i) To reduce the friction between the moving parts
- ii) To reduce the power required by moving parts to overcome the friction
- iii) To reduce the wear of engine components
- iv) To reduce the heat generation due to friction between moving parts
- v) To absorb the heat generated and helps in engine cooling
- vi) To act as seal between piston rings and cylinder walls/liners
- vii) To clean the engine components by removing the dust or any other foreign material entering in the engine cylinder

Engine lubrication can be classified into following two major categories :

- i) Splash lubrication system
- ii) Force feed lubrication system

#### ➤ **Types of engines lubrication system**

##### • **Splash lubrication system**

In splash lubrication system the lubrication oil is picked from the oil sump or a pan by a dipper provided at the bottom of the connecting rod for piston in each cylinder. The connecting rod picks the oil from the bottom and moves upward to the engine components. Some oils is also reached to different components like bearings, connecting rod through splash as mechanical turbulence is generated in the crankcase by the moving components which further makes the oil spread in the form of mist in the crankcase. This mist further reaches to other engine components like piston, piston pin and cylinder walls. The camshaft and valve mechanism is also lubricated by the oil. Although the splash type lubrication system is still being used in the engines these days but its usage has been found to be limited to small or single cylinder engines as the splash only is not sufficient to make oil to reach all critical components of the engine.

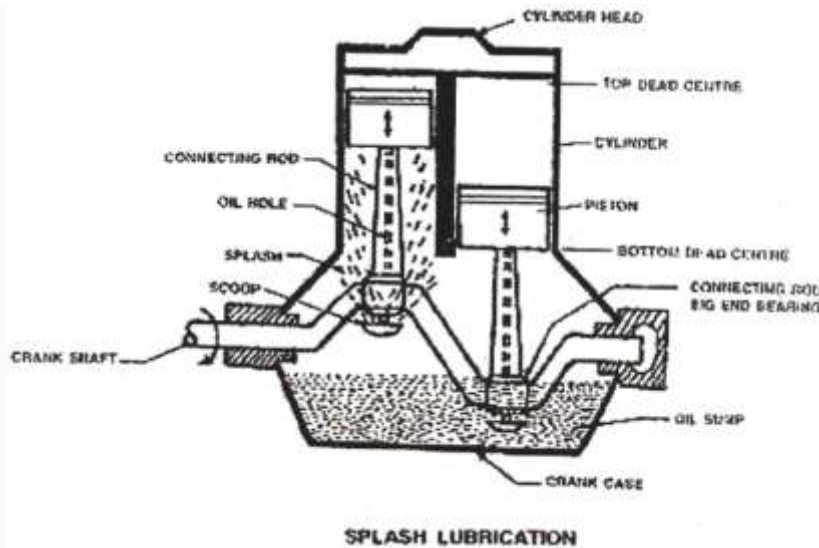

- **Force feed lubrication system**

As splash system has limitations to lubricate all the critical components in an engine, force feed system is used to generate additional pressure to ensure oil reaching to all essential and desired components for lubrication purposes. Generally, a gear type pump driven by the camshaft generates the pressure in oil to move from the crankcase to crankshaft, connecting rod, bearings pistons and valves. As the lubricating oil is supplied to the engine components under pressure, hence the reach of oil is enhanced to lubricate the remote and farthest points. This helps in efficient lubrication of engine components and hence in achieving better engine performance.

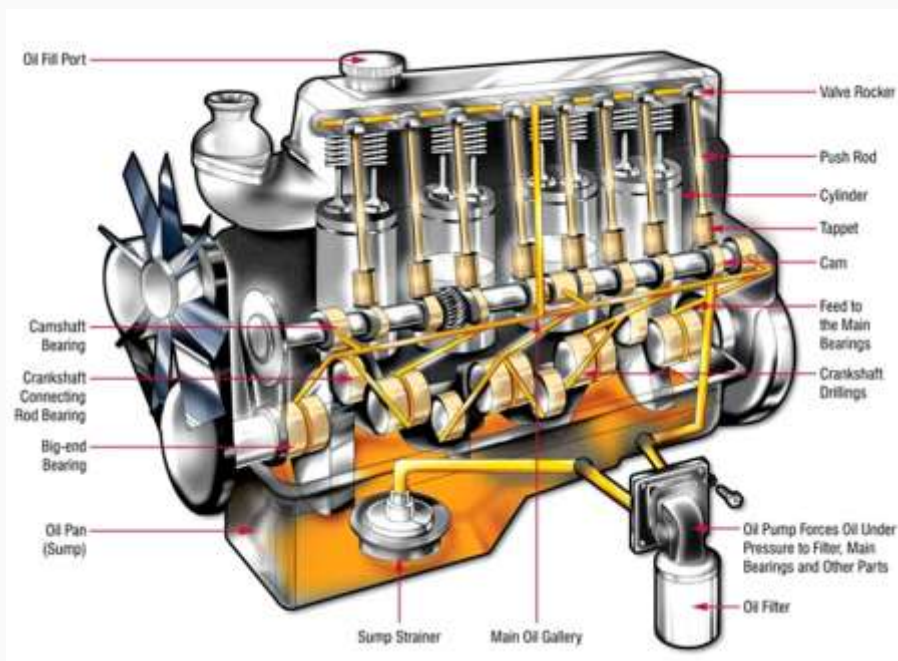

- **Properties of lubricants**

For smooth functioning of engine components, the efficient function of engine lubrication is must and for efficient functioning of lubrication system, the lubricants should also have the following properties.

- Viscosity
- Clean and stable
- Pour point
- Flashpoint
- Corrosion resistant

### **Viscosity**

Viscosity is the property of the oil which refers to the resistance it has to flow due which two surfaces are kept apart from each other. The viscosity of the lubricants oil should be sufficient to ensure hydrodynamic lubrication. Higher viscosity is also not desirable as it increases the friction and power loss. The oil viscosity decreases at higher temperature and loses its efficacy, so the lubricants should have resistance against the temperature. High viscosity lubricating oils also hampers the initial starting of the engine. Viscosity Index (VI) is a measure of the change of viscosity of oil with temperature. A high viscosity index means less change of oil viscosity with temperature rise. Petroleum lubricating oils generally have viscosity index from 100 to 110, which may be increased to 120 to 130 by means of additives.

### **Clean and stable**

The lubricating oils should be sufficiently clean and stable for the smooth and prolonged trouble free operation of the engine. Lubricating oils should be stable at lowest and highest temperature as the oil particles should not get separated at low temperature and get vaporised at high temperature. Generally, it is observed that at high temperature oils get oxidized which become sticky and damages the engine components, sometimes form carbon, which damages the piston rings causing compression loss. So the lubricating oils should be chemically stable also which do not change their properties at high temperature.

### **Pour Point**

It is the minimum temperature at which the fluid/oil pour and the liquid/oil below this temperature will not be able to flow. Hence the lubricants below this temperature can not be used and function for its desired purpose. Thus, the lubricating oil with pour point less than the lowest temperature encountered in the engine is selected.

### **Flash Point**

The flash point of the fluid/oil refers to the temperature at which it gets sparked and it should be sufficiently high so as to avoid flashing of oil vapours.

### **Corrosion Resistance**

The lubricating oil used in the automobile engines should have sufficient resistance to corrosion of the engine components like pipe lines, crank case etc. which are in regular contact with each other.

## LESSON 12

### IGNITION SYSTEM

#### ➤ Spark ignition – components & function

Engine is the device to convert heat energy of fuel into useful mechanical work. To use full potential of fuel to generate heat, full combustion of fuel is required which further needs proper ignition of the fuel. Poorly ignited fuel leads to loss of un-burnt fuel. So, engine ignition system is of high significance for getting maximum engine performance and efficiency. Engine ignition system has either of the following types.

- i) Spark ignition system
- ii) Compression ignition system

#### **Spark ignition system**

In petrol engines where air fuel mixture is compressed in the cylinder and an external/additional element i.e spark plug is used to ignite the fuel and generate power stroke. When the air fuel mixture (charge) is compressed, a high voltage spark jumps across the gap in spark plug to ignite the charge. This jumping of spark should happen at a particular and predetermined time. If the spark occurs early while starting the engine i.e when piston is yet to reach TDC, it would tend to result into a reverse kick. However, when engine is running at full load, the spark is advanced to make fuel to have sufficient time to burn and produce maximum heat energy which would further be transferred by the piston to generate maximum mechanical power. Following are the components of electric system being used in spark ignition system.

**Battery :** It is required to produce electric current to the ignition circuit which comprises of distributor, ignition switch, ignition coil, condenser, breaker point, spark plug and a generator. The composition of battery is same as used in tractors for compression ignition and discussed in the previous lecture no. 29.

**Distributor :** It is a rotating device used to open and close the electric circuit between the battery and ignition coil which further supply current to the primary winding of the coil. Magnetic field is produced with this surging of current in the primary coil and then the distributor opens the circuit to collapse the magnetic field and generate the high voltage current in the secondary winding of the coil. The distributor rotor then guides this high voltage to the spark plug.

**Ignition Coil :** It is used as voltage transfer device which transfers the low voltage ( 6 – 12 volts) current drawn from the battery to high voltage ( around 20,000 volts) current which is necessary to jump the gap between spark plug. The ignition coil is made up of laminated core which has several hundreds turn of heavy wire as primary winding and the secondary winding consists of thousands of turns of fine wire. Primary and secondary windings are insulated from each other and are also sealed fully.

**Condenser :** To have sudden collapse of magnetic field (which is mandatory to generate high voltage current in the secondary coil, a condenser is provided which is further connected with the breaker point. This condenser also helps in avoiding spark being produced at the breaker points which may damage these points. As these contact points are being used continuously, the gaps (0.3 to 0.5 mm) between these contact breaker points are to be checked regularly and dressed up.

**Generator :** The battery need to be charged regularly for which generator is provided in the electric system of an engine. Generator is provided with cutout which makes the generator to get

disconnected from the battery when the engine is running at very low speed. Generator is driven by a belt which is to be maintained at proper tension and bearing used should also be well lubricated.

**Spark plug :** This is used to generate the high voltage spark which is transferred from the tip of the spark plug to the engine combustion chamber. It consists of outer shell having threads and an electrode. It is available in different sizes as per the requirement of engine. As the point of spark plug is always exposed to the intense heat in the cylinder/combustion chamber, it may get damaged and carbon deposits are seen many times. These deposits are to be cleaned regularly and the gap should be kept between 0.5 to 0.85 mm. The spark plugs are to be tightened properly.

### **Magneto Ignition**

In magneto ignition system there is no battery being used but a magneto is there to generate its own small current which is further stepped up to high voltage enough to jump over the spark plug. The spark should be produced at a right and predetermined time. In magneto, a magnet is rotated so rapidly in a coil having turns of wire which generates the current just like it is produced in the battery ignition system. Similarly, a high voltage is also produced in the secondary winding of the magneto coil. A distributor is being used to carry this current to the spark plug. Magneto points are to be maintained properly as per the service schedule prescribed by the manufacturer.

### **➤ Compression ignition – components & function**

#### **Compression ignition system**

Diesel engines are compression ignition engines in which no external component is required for igniting the fuel. The air sucked by the engine during the downward motion of the piston in the suction is compressed by the piston when it moves upward during the compression stroke. With compression, the temperature of air rises to such a high level that when atomized fuel (diesel) is injected into the combustion chamber through the nozzles (injectors) the fuel is ignited.

To initiate the ignition in the first power stroke, an electrical system is required in diesel engines also which comprises of a battery and starting motor. An electric current of 500 amperes at 12 to 24 volts from the battery is provided to the starting motor which further actuates the cranking of piston and generates the first power stroke. If the engine does not start in the first attempt, subsequent attempts are made to make the connections between battery and starting motors but continuous and frequent attempts are to be avoided to prevent damage to the battery and motor. Once the engine is started, the battery gets disconnected from the motor and power strokes come in continuation as per the firing orders in multiple cylinders. However, in a single cylinder engine, the flywheel stores sufficient energy to complete the engine cycle. Sometimes glow plugs are also provided in the diesel engines to heat the air entering into the cylinder through inlet manifolds, particularly in winters or in the excessive cold areas. These glow plugs are connected with the battery. Following are the different types of compression ignition diesel engines.

i) Using electric motor driven by battery

ii) Starting by hand cranking using rotating lever

Electric motor with battery is most commonly used method in small, medium and large sized tractors. Whereas, hand cranking is used for small and stationary, single cylinder engines.

#### **Battery Ignition System**

Tractors these days are provided with a battery and starting motor to initiate the engine ignition process. Electric current from the battery is generated and it is used to run the starting motor which



further helps in initial cranking and hence ignites the fuel in engine. Once, the fuel is ignited in the engine, the starting motor gets disconnected from the engine.

**Battery :** Battery used in tractors is usually of three to six cells which develop around 2.2 volts each. Each cell is having positive and negative plates which are separated by the separators. Positive plates are made of lead and antimony and negative plates are generally made of spongy lead. Wooden or rubber material is being used to make separators. A mixture of sulphuric acid and distilled water is used as electrolyte with specific gravity of 1.280 when it is fully charged and it comes down to 1.150 or below when the battery gets fully discharged. The battery should be charged regularly and maintained properly by keeping the desired level (above the plate) of electrolyte in the battery case/body. The terminals of battery should be kept clean always.

**Starting motor :** 12 or 24 volts motors are used in tractors (diesel engines) which have a drive to actuate automatic engagement of pinion with the engine flywheel ring. This engagement of pinion with the ring gear initiates the engine cranking. Once the engine is started, the pinion is disengaged from the ring gear. The motors should generate sufficient power to crank the engine by moving the piston against heavy loads. Positive meshing of pinion and ring gear is must to crank the engine otherwise multiple attempts made continuously or in a short interval of time leads to discharge of battery.